



AGENDA
CHARTER TOWNSHIP OF MERIDIAN
TOWNSHIP BOARD – REGULAR MEETING
July 7, 2026 6:00 PM

1. CALL MEETING TO ORDER
2. PLEDGE OF ALLEGIANCE/INTRODUCTIONS
3. ROLL CALL
4. PRESENTATIONS
 - A. Introduction of New Firefighter

5. CITIZENS ADDRESS AGENDA ITEMS AND NON-AGENDA ITEMS
6. TOWNSHIP MANAGER REPORT
7. BOARD MEMBER REPORTS OF ACTIVITIES AND ANNOUNCEMENTS
8. APPROVAL OF AGENDA
9. CONSENT AGENDA
 - A. Communications
 - B. Minutes
 - (1) June 2, 2026 Township Board Closed Session Meeting
 - (2) June 16, 2026 Regular Township Board Meeting
 - (3) June 16, 2026 Township Board Closed Session Meeting
 - C. Bills
 - D. Verizon Competitive Bid Contract
 - E. 2120 Hospitality, LLC (Pins & Pints) Outdoor Assembly Permit
 - F. 2026 Board Meeting Schedule Update
 - G. Domain Controller Purchase Agreement with Brightline Technologies

10. BOARD ACTION ITEMS
 - A. Zoning Amendment #2026-05 - Backyard Chicken and Rabbits Update – RECONSIDERATION
 - B. Sanctuary #2 Public Streetlighting Improvement Special Assessment District #430 – Resolution #4
 - C. Sierra Ridge #4 Public Streetlighting Improvement Special Assessment District #431 – Resolution #4

11. BOARD DISCUSSION ITEMS
 - A. Park and Public Safety Millage Renewals

12. COMMENTS FROM THE PUBLIC
13. OTHER MATTERS AND BOARD MEMBER COMMENTS
14. CLOSED SESSION-Motion to enter closed session under MCL 15.268(1)(h) to consult with the Township attorney regarding a confidential written legal opinion.

15. ADJOURNMENT

All comments limited to 3 minutes, unless prior approval for additional time for good cause is obtained from the Supervisor. Appointment of Supervisor Pro Tem and/ or Temporary Clerk if necessary. Individuals with disabilities requiring auxiliary aids or services should contact the Meridian Township Board by contacting: Township Manager Tim Dempsey, 5151 Marsh Road, Okemos, MI 48864 or 517.853.4258 - Ten Day Notice is Required.

Meeting Location: 5151 Marsh Road, Okemos, MI 48864 Township Hall

Providing a safe and welcoming, sustainable, prime community.



A PRIME COMMUNITY
meridian.mi.us



9.A

**CONSENT AGENDA
BOARD
COMMUNICATIONS**



CHARTER TOWNSHIP OF MERIDIAN, INGHAM COUNTY

LEGAL AD NOTICE: Mixed Use Planned Unit Development #26021
(SP Holding Company)

TUESDAY, July 16, 2026

CHARTER TOWNSHIP OF MERIDIAN
LEGAL NOTICE
Mixed Use Planned Unit Development #26021
(SP Holding Company)
Public Hearing

Notice is hereby given that the Director of the Department of Community Planning and Development of the Charter Township of Meridian will hold a public hearing on Thursday July 16, 2026 at 3:00 p.m. in the Meridian Municipal Building, Town Hall Room, 5151 Marsh Road, Okemos, MI 48864 (phone 517-853-4560) to hear all persons interested in a request from SP Holding Company for a minor amendment to the mixed use planned unit development approval for the Haslett Village project.

The developer is proposing to reduce the number of residential units from 290 to 185. The approximate 19.04-acre project site is zoned C-2, Commercial, and is located on the southwest corner of Marsh Road and Haslett Road at 1621 & 1655 Haslett Road. The following parcels are included in the project: 33-02-02-10-401-008 and 33-02-02-10-401-009.

Information may be examined at the Department of Community Planning and Development, 5151 Marsh Road, Okemos, Michigan 48864-1198, between the hours of 8:00 a.m. and 5:00 p.m., Monday through Friday and on the Township website at <https://www.meridian.mi.us/government/at-your-fingertips/current-applications-before-meridian-township>. Written comments may be sent prior to the public hearing to Brian Shorkey, AICP, Principal Planner, Charter Township of Meridian, 5151 Marsh Road, Okemos, Michigan, 48864, or by email to shorkey@meridian.mi.us.

Publish: City Pulse
July 1, 2026

Angela Demas
Township Clerk

1 Affidavit, please



CHARTER TOWNSHIP OF MERIDIAN, INGHAM COUNTY

LEGAL AD NOTICE: Special Use Permit #26022

(Porter Avenue Group Child Care)

MONDAY, July 27, 2026

CHARTER TOWNSHIP OF MERIDIAN

LEGAL NOTICE

Special Use Permit #26022 (Porter Avenue Group Child Care)

Public Hearing

Notice is hereby given that the Planning Commission of the Charter Township of Meridian will hold a public hearing on Monday, July 27, 2026 at 6:30 p.m. in the Meridian Municipal Building, Town Hall Room, 5151 Marsh Road, Okemos, MI, 48864 (phone 517-853-4560) to hear all persons interested in a request from Kathryn Krock to operate a group child care home for up to fourteen children located at 6364 Porter Avenue. The approximate 0.3 acre site is zoned RA (Single-Family Residential).

Information may be examined at the Department of Community Planning and Development, 5151 Marsh Road, Okemos, Michigan 48864-1198, between the hours of 8:00 a.m. and 5:00 p.m., Monday through Friday.

Comments may be sent prior to the public hearing by writing to the Planning Commission, Charter Township of Meridian, 5151 Marsh Road, Okemos, Michigan, 48864, by phone at phone 517-853-4576, or by email at shorkey@meridian.mi.us. Comments may also be given in person at the public hearing.

Publish: City Pulse
July 8, 2026

Angela Demas
Township Clerk

1 Affidavit, please



CHARTER TOWNSHIP OF MERIDIAN, INGHAM COUNTY

**LEGAL AD NOTICE: Zoning Amendment #26015
Mass Timber Construction**

MONDAY, July 27, 2026

**CHARTER TOWNSHIP OF MERIDIAN
LEGAL NOTICE
Zoning Amendment #26015 – Mass Timber Construction
Public Hearing**

Notice is hereby given that the Planning Commission of the Charter Township of Meridian will hold a public hearing on Monday, July 27, 2026 at 6:30 p.m. in the Meridian Municipal Building, Town Hall Room, 5151 Marsh Road, Okemos, MI, 48864 to hear all persons interested in a proposed zoning amendment. The Meridian Township Planning Commission has proposed to amend several sections of Article VIII of the Zoning Ordinance to include a definition of mass timber construction and to allow mass timber construction as an allowed amenity in for commercial planned unit developments.

A complete copy of the amendment may be viewed at the Community Planning and Development office, 5151 Marsh Road, Okemos, Michigan 48864-1198 (phone 517-853-4560), between the hours of 8:00 a.m. and 5:00 p.m., Monday through Friday. Written comments may be sent prior to the public hearing to the Planning Commission, Charter Township of Meridian, 5151 Marsh Road, Okemos, Michigan, 48864, or by email to shorkey@meridian.mi.us.

Publish: City Pulse
July 8, 2026

**Angela Demas
Township Clerk**

1 Affidavit, please



**CHARTER TOWNSHIP OF MERIDIAN, INGHAM COUNTY
LEGAL AD NOTICE: NOTICE OF REGISTRATION
FOR THE AUGUST 4, 2026, PRIMARY ELECTION**

PLEASE TAKE NOTICE that any qualified elector who is not already registered, may register to vote at the office of the Meridian Township Clerk; the office of the County Clerk; a Secretary of State Branch Office, or other designated state agency. Qualified electors who have a valid Michigan driver's license or state ID, may register online at <https://mVIC.sos.state.mi.us/>. Registration forms may be obtained at mi.gov/vote and mailed or dropped off at the office of the Meridian Township Clerk. Voters who are already registered may update their registration at www.expressSOS.com.

The last day to register in any manner other than in-person with the Meridian Township Clerk's Office is Monday, July 20, 2026. After this date, anyone who qualifies as an elector must register to vote in person with proof of residency (MCL 168.492) at the following location and times:

Meridian Township Clerk's Office - 5151 Marsh Road, Okemos, MI 48864

- Regular Business Hours: Monday through Friday from 8:00 a.m. to 5:00 p.m.
- Saturday, August 1st and Sunday, August 2nd from 9:00 a.m. to 5:00 p.m.
- Election Day, Tuesday, August 4th from 7:00 a.m. to 8:00 p.m.

TO THE QUALIFIED ELECTORS OF THE CHARTER TOWNSHIP OF MERIDIAN:

PLEASE TAKE NOTICE that Meridian Township will hold a Primary Election on August 4, 2026.

For the purposes of nominating candidates for the following office:

- **GOVERNOR**
- **UNITED STATES SENATOR**
- **REPRESENTATIVE IN CONGRESS**
- **STATE SENATOR**
- **REPRESENTATIVE IN STATE LEGISLATURE**
- **TOWNSHIP TREASURER**
- **DELEGATE TO COUNTY CONVENTION**

For the purposes of voting on the following proposals as listed below:

- **INGHAM COUNTY POTTER PARK ZOO AND POTTER PARK OPERATIONAL MILLAGE RENEWAL AND RESTORATION QUESTION**
- **INGHAM COUNTY COUNTYWIDE SYSTEM OF TRAILS AND PARKS MILLAGE RENEWAL AND RESTORATION QUESTION**
- **INGHAM COUNTY PUBLIC TRANSPORTATION SYSTEM FOR ELDERLY AND DISABLED MILLAGE RENEWAL AND RESTORATION QUESTION**
- **INGHAM COUNTY TOURISM, ENTERTAINMENT FACILITIES, AND ARTS PROPOSAL**
- **CAPITAL AREA DISTRICT LIBRARY BALLOT PROPOSAL FOR A DISTRICT WIDE TAX**

The full text of the ballot proposals and sample ballots can be found at www.mi.gov/vote or can be viewed at the Meridian Township Clerk's Office, 5151 Marsh Road, Okemos, MI 48864.

Persons with disabilities needing accommodations should contact the Clerk's Office.

ABSENT VOTER BALLOTS:

Any registered voter may request an Absent Voter Ballot. The Meridian Township Clerk's Office must have a signed application to issue an Absent Voter Ballot. You may apply online at www.mi.gov/vote or at



**CHARTER TOWNSHIP OF MERIDIAN, INGHAM COUNTY
LEGAL AD NOTICE: NOTICE OF REGISTRATION
FOR THE AUGUST 4, 2026, PRIMARY ELECTION**

the Meridian Township Clerk's Office.

Monday, August 3, 2026, at 4 pm is the deadline to request an absentee ballot in person, except for those who register to vote on Election Day. Those registering to vote on Election Day, August 4, 2026, are eligible to receive an Absent Voter Ballot at the Meridian Township Clerk's Office.

EARLY VOTING CENTER

All qualified electors in the Meridian Township Clerk's Office have the option to vote early in person, beginning Saturday, July 25th through Sunday, August 2nd, 2026.

On Saturday, July 25th, 2026, the Early Voting Center will be open from 7:00 a.m. – 3:00 p.m., due to preparation for the Celebrate Meridian Festival. Central Park Drive will be closed, and voters must enter through the Marsh Road entrance. Parking will be reserved for early voters.

From Sunday, July 26th through Sunday, August 2nd, 2026, the Early Voting Center will be open from 9:00 a.m. – 5:00 p.m.

The Early Voting Center will be held at the Meridian Township Municipal Building – 5151 Marsh Road, Okemos, MI 48864.

Publish: City Pulse

**Angela Demas
Meridian Township Clerk**



9.B

CONSENT AGENDA PROPOSED BOARD MINUTES

PROPOSED MOTION:

(1) Move to approve and ratify the minutes of the Closed Session of June 2, 2026, Closed Session of June 16, 2026, and Regular Meeting of June 16, 2026 as submitted.

ALTERNATE MOTION:

(1) Move to approve and ratify the minutes of the Closed Session of June 2, 2026, Closed Session of June 16, 2026, and Regular Meeting of June 16, 2026 with the following amendment(s):[insert amendments]

CHARTER TOWNSHIP OF MERIDIAN
REGULAR MEETING TOWNSHIP BOARD -**DRAFT**-
5151 Marsh Road, Okemos MI 48864-1198
517.853.4000, Township Hall Room
TUESDAY, June 16, 2026, 6:00PM

PRESENT: Supervisor Hendrickson, Treasurer Burghardt, Trustee Lentz, Trustee Sundland,
Trustee Trezise, and Trustee Wilson

ABSENT: Clerk Demas

STAFF: Township Manager Dempsey, Deputy Manager and Department of Public Works
Director Opsommer, I.T. Director Gebes, Senior Project Engineer Hart, and Land
Stewardship Coordinator Campbell

1. CALL MEETING TO ORDER

Supervisor Hendrickson called the June 16, 2026, Regular Township Board meeting to order at
6:00 pm.

2. PLEDGE OF ALLEGIANCE/INTRODUCTIONS

Supervisor Hendrickson led the Pledge of Allegiance.

3. ROLL CALL

A. Appointment of a Temporary Clerk to Trustee Trezise

B. Trustee Trezise acting as Temporary Clerk called the roll. Six Board Members present.

Clerk Demas was absent.

4. PRESENTATIONS

A. Introduction of New Firefighter - Nicholas Dramer.

Chief Hamel introduced Nicholas Dramer as their new Firefighter.

B. ITC Oneida-Sabine Lake Project Update.

LGCA Area Manager Breina Pugh presented an update on the Oneida-Sabine Lake Project.

Board discussion occurred regarding the project process.

C. CADL Annual Report.

Capital Area District Library (CADL) Executive Director Jenny Maher and Regional Head
Librarian Tom Moore presented the 2025 Annual Report and reminded the Board of the CADL
proposal on the August 4, 2026 ballot.

5. CITIZENS ADDRESS AGENDA ITEMS AND NON-AGENDA ITEMS

Supervisor Hendrickson opened public comment at 6:22pm.

Neil Bowlby spoke in opposition to item 12A Land Preservation Acquisition.

Supervisor Hendrickson closed public comment at 6:26pm.

6. TOWNSHIP MANAGER REPORT

Manager Dempsey spoke about the following:

- Thanked Director Clark and Parks and Recreation for the Juneteenth Celebration.
- Reminder that the Township Offices are closed on June 19th in observance of the Juneteenth holiday
- Home TV candidate interviews for the August Election are now available online.
- Meridian Energy Team and Green Team will hold an annual energy fair at the June 20th Farmers' Market.

7. BOARD MEMBER REPORTS OF ACTIVITIES AND ANNOUNCEMENTS

Trustee Lentz reminded the Board of the Ingham County MTA meeting scheduled for June 25th. He also expressed his appreciation for the Meridian Pride event and thanked the sponsors of the event.

Supervisor Hendrickson thanked Director Clark and staff for the Juneteenth event.

8. APPROVAL OF AGENDA

Trustee Wilson moved to approve the agenda. Supported by Trustee Lentz.

VOICE VOTE: YEAS: Supervisor Hendrickson, Treasurer Burghardt, Trustee Lentz, Trustee Sundland, Trustee Trezise, and Trustee Wilson.

NAYS: NONE

Motion carried: 6-0

9. CONSENT AGENDA

Supervisor Hendrickson listed the consent agenda items.

Trustee Wilson moved the consent agenda. Supported by Trustee Sundland.

ROLL CALL VOTE: YEAS: Supervisor Hendrickson, Treasurer Burghardt, Trustee Lentz, Trustee Sundland, Trustee Trezise, and Trustee Wilson.

NAYS: NONE

Motion carried: 6-0

10. Hearing

A. 2026 Order to maintain Sidewalk Special Assessment District #22 - Public Hearing

Engineer Hart gave a brief overview of the project.

Supervisor Hendrickson opened the Public Hearing at 6:34 pm.

The opportunity to speak during public comment was given.

Supervisor Hendrickson closed the Public Hearing at 6:34 pm.

11. BOARD ACTION ITEMS

A. Ordinance #2026-07 Garza Family-1745 Mack Avenue Rezoning – Adoption

Director Schmitt gave an overview of the item as previously discussed to rezone the property at 1745 Mack Avenue from RDD, Multiple Family Residential to RB, One-Family, High Density Residential.

The Board indicated general support for the rezoning.

Trustee Lentz moved to adopt the resolution approving Ordinance 2026-07, an ordinance to rezone 1745 Mack Avenue Parcel ID# 33-02-02-03-251-001 from RDD, Multiple Family Residential, up to five dwelling units per acre, to RB, One-Family, High Density Residential. Supported by Trustee Wilson.

ROLL CALL VOTE: YEAS: Supervisor Hendrickson, Treasurer Burghardt, Trustee Lentz, Trustee Sundland, Trustee Trezise, and Trustee Wilson.

NAYS: NONE

Motion carried: 6-0

B. Zoning Amendment #2026-06-Parking Standards Update-Adoption

Director Schmitt gave an overview of the item and stated that this ordinance has gone through a lot of changes with this being the last part that needs to be completed.

Board discussion occurred recognizing the changes and indicated general support.

Trustee Trezise moved to approve the resolution approving Text Amendment #2026-06 to amend the Code of Ordinances of the Charter Township of Meridian at Article VIII of Chapter 86 to update the standards for parking and parking lots in the Township. Supported by Trustee Wilson.

ROLL CALL VOTE: YEAS: Supervisor Hendrickson, Treasurer

Burghardt, Trustee Lentz, Trustee Sundland, Trustee Trezise, and Trustee Wilson.

NAYS: NONE

Motion carried: 6-0

C. 2026 Order to Maintain Sidewalk Special Assessment District #22 – Resolution #3

Engineer Hart gave an overview and explained that if Resolution #3 is adopted it would direct our DPW department to send out a Notice to Repair to the residents within the assessment roll to either repair the sidewalk or hire it out to be repaired before the Township repairs the sidewalk and puts the cost to the resident.

Board discussion occurred regarding repairs and cost.

The Board indicated general support.

Trustee Wilson moved to approve the 2026 order to maintain Sidewalk Special Assessment District #21, Resolution #3, which approves repair and maintenance of sidewalk in portions of the following areas: Carriage Hill Estates, Carriage Hill Estates, No. 2, Carriage Hill Estates No. 3, Crestwood, No. 2, Crestwood No. 3, Crestwood No. 5, Everett Farms No. 4, Everett Hills, Everett Woods, Heritage Hills, Heritage Hills No. 3, Heritage Hills No. 4, Sierra Ridges Estates Stormwater Detention, Sierra Ridge Estates No. 2, Whitehills Lakes, Whitehills Lakes No. 1, Wood Creek, and to defray the cost by Special Assessment; Approves the cost estimate of \$11,457.17; determines the Special Assessment District; directs the making of an Assessment Roll; and directs notices be sent to the property owners indicating that they have 20 days to replace or make safe the defective sidewalk. Supported by Trustee Lentz.

ROLL CALL VOTE: YEAS: Supervisor Hendrickson, Treasurer Burghardt, Trustee Lentz, Trustee Sundland, Trustee Trezise, and Trustee Wilson.

NAYS: NONE

Motion carried: 6-0

D. Zoning Amendment #2026-05 – Backyard Chicken and Rabbits Update – Adoption

Director Schmitt gave an overview and explained that the updated amendment will allow backyard chickens and rabbits in RB and RX districts in which it was previously prohibited.

The Board indicated general support for the item.

Treasurer Burghardt moved to adopt the resolution to approve Text Amendment #2026-05 to amend the Code of Ordinances of the Charter Township of Meridian at Section 86-368 to update the standards for the keeping of backyard chickens and rabbits in the Township. Supported by Trustee Wilson.

ROLL CALL VOTE: **YEAS: Supervisor Hendrickson, Treasurer Burghardt, Trustee Lentz, Trustee Sundland, Trustee Trezise, and Trustee Wilson.**

NAYS: NONE

Motion carried: 6-0

11. BOARD DISCUSSION ITEMS

A. Land Preservation Acquisition – Hamilton Road

Stewardship Coordinator Campbell gave an overview and explained how the acquisition process has changed as well as provided information on the Land Preservation Advisory Board.

Board discussion occurred regarding the appraisal value, invasive species, signage, land acquisition fund balance, and overall indicated no issues with the acquisition.

12. COMMENTS FROM THE PUBLIC

Supervisor Hendrickson opened public comment at 7:16 pm.

The opportunity to speak was provided to the public.

Supervisor Hendrickson closed public comment at 7:16 pm.

13. OTHER MATTERS AND BOARD MEMBER COMMENTS

None.

14. CLOSED SESSION

Trustee Lentz moved to enter closed session under MCL 15.268(1)(h) to consult with the Township attorney regarding a confidential written legal opinion. Supported by Trustee Wilson.

ROLL CALL VOTE: **YEAS: Supervisor Hendrickson, Treasurer Burghardt, Trustee Lentz, Trustee Sundland, Trustee Trezise, and Trustee Wilson.**

NAYS: NONE

Motion carried: 6-0

At 7:17 pm, the Board entered closed session.

At 8:23 pm, the Board returned to open session.

Treasurer Burghardt left the meeting.

15. ADJOURNMENT

Trustee Lentz moved to adjourn. Supported by Trustee Wilson.

VOICE VOTE

**YEAS: Supervisor Hendrickson,
Trustee Lentz, Trustee Sundland, Trustee Trezise, and
Trustee Wilson.**

NAYS: NONE

Motion carried: 5-0

The meeting adjourned at 8:23 pm.

Scott Hendrickson
Township Supervisor

Angela Demas
Township Clerk



To: Board Members
From: Bernadette Blonde, Finance Director
Date: July, 7 2026

Charter Township of Meridian
Board Meeting
7/7/2026

MOVE THAT THE TOWNSHIP BOARD APPROVE THE TOWNSHIP INVOICES/EXPENSES AS FOLLOWS:

COMMON CASH	\$	1,014,600.59
PUBLIC WORKS	\$	1,069,803.58
TRUST & AGENCY	\$	32,573.01
TOTAL CHECKS:	\$	2,116,977.18
CREDIT CARD TRANSACTIONS 6/12/2026 to 7/2/2026	\$	20,524.57
TOTAL PURCHASES:	\$	<u>2,137,501.75</u>
ACH PAYMENTS	\$	<u>2,055,737.11</u>

BANK CODE: GF53 - CHECK TYPE: PAPER CHECK

Vendor Name	Description	Amount
1. 42 NORTH CONSTRUCTION LLC	**HARD COPY CHECK REQUEST** TO 42 NORTH CONSTRUCIT	14,905.00
2. 911 TRAINING INSTITUTE INC	POLICE OFFICER PRE-EMPLOYMENT EVALUATION	650.00
3. A T & T	JUN 7 - JUL 6 2026 - INTERNET F2 327774829	149.00
	JUN 7 - JUL 6 2026 - INTERNET P1 327774999	195.25
	JUN 9 - JUL 8 2026 - INTERNET F1 327775054	195.25
	JUN 15 - JUL 14 2026 - INTERNET S1 327950862	205.24
	TOTAL	744.74
4. ALL CITY MANAGEMENT SERVICES INC	SCHOOL CROSSING GUARD SERVICES MAY 3 -MAY 16 2026	4,941.95
	SCHOOL CROSSING GUARD SERVICES MAY 17 -MAY 30 2026	4,447.75
	SCHOOL CROSSING GUARD SERVICES MAY 31 - JUNE 13 202	1,959.04
	TOTAL	11,348.74
5. ALLGRAPHICS CORP	DPW LOGO WEAR	313.75
	2026 DPW LOGO WEAR - UNIFORMS	512.00
	HNC SUMMER CAMP STAFF LOGO WEAR	254.20
	2026 HARRIS NATURE CENTER SUMMER CAMP SHIRTS	1,407.25
	TOTAL	2,487.20
6. ALYSHA COWLES	FARMERS MARKET VENDOR	25.00
7. APPLIED CONCEPTS	STALKER SPEED MODULE WITH EXTERNAL ANTENNA	242.25
8. ASAP PRINTING	INSPECTION STICKERS FOR THE EAST LANSING TRADE INSP	480.00
9. AT & T	MAY 19 - JUL 14 2026 - ABV P1 8310016264190	291.34
	JUN 4 - JUL 14 2026 - ABV F2 8310016264197	107.54
	JUN 7 - JUL 6 2026 - TELEPHONE + INTERNET M1 831001	852.27
	VARIOUS MAY DATES TO JUL 14 2026 - ABV S1 F1 F3 831	554.32
	MAY 11 - JUN 10 2026 - INTERNET ASE 8310008214218	3,763.02
	JUN 7 - JUL 6 2026 - TELEPHONE + INTERNET M1 831001	1,142.81
	MAY 15 - JUL 14 2026 - ABV M1 8310016264194	157.70
	TOTAL	6,869.00
10. AT & T MOBILITY	JUN 5 - JUL 4 2026 - WIRELESS 287252740666 517.332.	314.94
	MAY 7 - JUN 6 2026 - FIRSTNET 287312082574 517.575.	75.48
	TOTAL	390.42

BANK CODE: GF53 - CHECK TYPE: PAPER CHECK

Vendor Name	Description	Amount
11. AUTO VALUE OF EAST LANSING		
	MOTOR POOL - FLEET REPAIR PARTS 2026 - 1ST PO	9.99
	MOTOR POOL - FLEET REPAIR PARTS 2026 - 1ST PO	39.09
	MOTOR POOL - FLEET REPAIR PARTS 2026 - 1ST PO	601.95
	MOTOR POOL - FLEET REPAIR PARTS 2026 - 1ST PO	60.67
	MOTOR POOL - FLEET REPAIR PARTS 2026 - 1ST PO	659.44
	MOTOR POOL - FLEET REPAIR PARTS 2026 - 1ST PO	153.99
	MOTOR POOL - FLEET REPAIR PARTS 2026 - 1ST PO	208.98
	MOTOR POOL - FLEET REPAIR PARTS 2026 - 1ST PO	(208.98)
	MOTOR POOL - FLEET REPAIR PARTS 2026 - 1ST PO	11.89
	MOTOR POOL - FLEET REPAIR PARTS 2026 - 1ST PO	79.16
	MOTOR POOL - FLEET REPAIR PARTS 2026 - 1ST PO	11.79
	MOTOR POOL - FLEET REPAIR PARTS 2026 - 1ST PO	71.34
	MOTOR POOL - FLEET REPAIR PARTS 2026 - 1ST PO	7.38
	MOTOR POOL - FLEET REPAIR PARTS 2026 - 1ST PO	17.97
	MOTOR POOL - FLEET REPAIR PARTS 2026 - 1ST PO	189.29
	MOTOR POOL - FLEET REPAIR PARTS 2026 - 1ST PO	180.00
	MOTOR POOL - FLEET REPAIR PARTS 2026 - 1ST PO	23.78
	MOTOR POOL - FLEET REPAIR PARTS 2026 - 1ST PO	27.47
	MOTOR POOL - FLEET REPAIR PARTS 2026 - 1ST PO	19.87
	MOTOR POOL - FLEET REPAIR PARTS 2026 - 1ST PO	36.18
	MOTOR POOL - FLEET REPAIR PARTS 2026 - 1ST PO	46.69
	MOTOR POOL - FLEET REPAIR PARTS 2026 - 1ST PO	120.00
	MOTOR POOL - FLEET REPAIR PARTS 2026 - 1ST PO	115.22
	MOTOR POOL - FLEET REPAIR PARTS 2026 - 1ST PO	369.99
	MOTOR POOL - FLEET REPAIR PARTS 2026 - 1ST PO	424.99
	MOTOR POOL - FLEET REPAIR PARTS 2026 - 1ST PO	85.32
	MOTOR POOL - FLEET REPAIR PARTS 2026 - 1ST PO	142.68
	TOTAL	3,506.14
12. AVALON TECHNOLOGIES INC		
	MCT-SQL HARDWARE SERVER SUPPORT RENEWAL - 07/04/202	4,420.00
13. BENSON HILLS APARTMENTS		
	EMERGENCY RENTAL ASSISTANCE	1,367.63
14. BETTERFINDS LLC		
	FARMERS MARKET VENDOR	76.00
15. BOARD OF WATER & LIGHT		
	2026 BWL STREETLIGHT SERVICE	935.80
16. BOSS CIDER COMPANY, LLC		
	FARMERS MARKET VENDOR	19.00
17. BOUNDTREE MEDICAL		
	MISC MEDICAL SUPPLIES (CO MONITOR, BLOOD GLUCOSE TE	4,502.52
18. BOYNTON FIRE SAFETY SERVICE		
	ANNUAL BACKFLOW INSPECTION AT TOWNER ROAD PARK	85.00
19. BRD PRINTING, INC		
	RETURN ENVELOPES-ASSESSING	159.87
20. BROOKLYN HORWATH		
	2026 YOUTH SOCCER REF 2 X 25 AND 9 X 37	383.00
21. CATHEY INDUSTRIAL SUPPLIES, CO		
	MP - WATER - COUPLERS FOR VACTOR PUMP OFF HOSE	31.20
22. CDW		
	BLUETOOTH ADAPTER FOR SGT. STROUSE PC	15.42
	FIRE T91 IPAD MOUNT	148.77
	FIRE IPAD CASES	236.58
	TOTAL	400.77
23. CEDAR CREEK APARTMENTS		
	EMERGENCY RENTAL ASSISTANCE	462.00
24. CHAU CONSTRUCTION SERVICES LLC		
	HAND CHECK FOR MAILING PLEASE CHILL 3100 BIRCH	8,212.62
25. CHICKADEE GOATMILK SOAP		
	FARM MARKET VENDOR	25.00

BANK CODE: GF53 - CHECK TYPE: PAPER CHECK

Vendor Name	Description	Amount
26. CINTAS CORPORATION #725	MECHANICS UNIFORM RENTAL	54.89
	MECHANICS UNIFORM RENTAL	54.89
	MECHANICS UNIFORM RENTAL	54.89
	FIRST AID KIT RESTOCK	292.74
	FIRST AID KIT RESTOCK	232.66
	FIRST AID KIT RESTOCK	211.56
	FIRST AID KIT RESTOCK	29.77
	TOTAL	931.40
27. CINZORI FARMS LLC	FARM MARKET VENDOR	236.00
28. CITY PULSE	TWP NOTICES	911.31
29. COLOR OF SOUND AUDIO	2026 CELEBRATE MERIDIAN FESTIVAL STAGE AND AUDIO CE	1,600.00
30. COMCAST	JUL 2026 - INTERNET + TV M1 8529114160156422	824.56
	JUN 29 - JUL 28 2026 - TELEPHONE + INTERNET S2 8529	435.85
	JUN 29 - JUL 28 2026 - TV F1 8529114160257253	44.85
	JUN 16 - JUL 15 2026 - INTERNET + TV F1 85291141602	179.85
	JUN 20 - JUL 19 2026 - TV F1 8539114160280677	14.95
	JUN 19 - JUL 18 2026 - INTERNET SCADA 8529114160296	476.90
	TOTAL	1,976.96
31. COMCAST	JUN 14 - JUL 13 2026 - INTERNET + TV HOMTV 85290100	504.45
32. CONSUMERS ENERGY	2026 ANNUAL LICENSE FEE FOR HULETT PATHWAY (S OF OK	700.12
33. COURTNEY WISINSKI	2026 PRIDE FESTIVAL SUPPLIES REIMBURSE	215.56
34. DANIEL J SODINI	FARMERS MARKET VENDOR	95.00
35. DARIN LARNER SR	SUMMER CONCERT SERIES - AUGUST 19, 2026 PERFORMER	150.00
36. DAVID OR ANN BROGREN	FARMERS MARKET VENDORS	96.00
37. DEERE & COMPANY	CHECK REISSUE - MP - PARKS - GATORS	49,528.75
	REISSUE CHECK - MP - GLENDALE/GROUNDS - GATORS	32,132.69
	TOTAL	81,661.44
38. DELL MARKETING LP	2026 DELL PRO SLIM QCS1250 DESKTOP - QT 20 UNITS	24,745.00
39. DEPARTMENT OF TREASURY	PATIENT-CENTERED OUTCOMES RESEARCH INSTITUTE FEE	1,044.48
40. DINGES FIRE COMPANY	FIRE GLOVES (QTY: 2), EXTRICATION GLOVES (QTY: 2),	322.49
41. DOMINIQUE HOUSE	JUNETEENTH '26 VENDOR	650.00
42. DON MIDDLEBROOK	SUMMER CONCERT SERIES - SEPTEMBER 9, 2026 PERFORMER	150.00
43. DOUGHNATION BAKERY	FARM MARKET VENDOR	82.00
44. ELECTRICAL TERMINAL SERVICE	MP - SHOP SUPPLIES	64.97
	MP - WATER - 690 - REAR VIEW CAMERA	353.44
	MP- UPFIITTING 3 NEW GATORS WITH SAFETY LIGHTS	3,508.29
	MP - SUPPLIES	449.97
	MP - STOCK - ELECTRICAL CONNECTORS	11.99
	TOTAL	4,388.66
45. ERVIN BOYD, JR	MUSICIAN AT JUNETEENTH 2026	600.00

Vendor Name	Description	Amount
46. FAHEY SCHULTZ BURZYCH RHODES PLC	LEGAL FEES	2,162.00
	LEGAL FEES	23.00
	LEGAL FEES	46.00
	LEGAL FEES	340.00
	LEGAL FEES	405.00
	LEGAL FEES	67.50
	LEGAL FEES	161.00
	LEGAL FEES	69.00
	LEGAL FEES	282.00
	LEGAL FEES	445.92
	LEGAL FEES	1,196.94
	LEGAL FEES	881.63
	LEGAL FEES	1,207.14
	LEGAL FEES	633.67
	LEGAL FEES	187.76
	LEGAL FEES	164.29
	LEGAL FEES	46.94
	LEGAL FEES	985.71
	LEGAL FEES	828.00
	LEGAL FEES	92.00
	LEGAL FEES	598.00
	LEGAL FEES	138.00
	LEGAL FEES	460.00
	LEGAL FEES	414.00
	LEGAL FEES	560.00
	LEGAL FEES	138.00
	LEGAL FEES	46.00
	LEGAL FEES	322.00
	LEGAL FEES	1,527.00
	TOTAL	14,428.50
47. FIONA WHITMYER	2026 YOUTH SOCCER REF FEE 5 X 25	125.00
48. FIRST COMMUNICATIONS	JUNE 2026 - TELEPHONE LINES 3142216	56.18
49. FISHBECK, THOMPSON, CARR & HUBER	INVOICE 451032 PROFESSIONAL SERVICES RENDERED THRU.	1,435.50
	PROFESSIONAL SERVICES THRU 4.24.26 DOBIE ROAD/FEDE	2,583.95
	TOTAL	4,019.45
50. FLAT OUT GRAPHICS	2026 YOUTH U12 BASEBALL UNIFORMS	933.50
51. FORESIGHT GROUP	WATER BILLS AND POSTAGE FOR 2026	653.62
	WATER BILLS AND POSTAGE FOR 2026	1,528.89
	MP - UPFITTING NEW INTERCEPTOR - 758	1,156.72
	LAKE LANSING BOAT LAUNCH SIGNAGE	338.93
	TOTAL	3,678.16
52. FRESHIES BAKERY	FARMERS MARKET VENDORS	29.00
53. G3 FOOD FOR ALL OF MICHIGAN	FARMERS MARKET VENDORS	29.00
54. GHD SERVICES INC	ACCESSIBILITY SCAN FOR WEBSITE	2,848.00
55. GRANGER WASTE SERVICES	GROUNDS - CENTRAL FIRE PROPERTY - REMOVE HOMELESS S	219.41
56. HIGHWATER FARMS	FARMERS MARKET	123.00
57. HILLARY DOYLE	FARMERS MARKET	64.00

BANK CODE: GF53 - CHECK TYPE: PAPER CHECK

Vendor Name	Description	Amount
58. HUTSON INC OF MICHIGAN	MP - BUILDINGS - 759	1,015.43
	MP - PARKS - 755	21.10
	MP - SHOP SUPPLIES	29.99
	TOTAL	1,066.52
59. IGNITE DONUTS LLC	FARMERS MARKET	75.00
60. JACOB FARLEY	FARM MARKET VENDOR	74.00
61. JEFF CLARK	FARMERS MARKET VENDOR	5.00
62. JESSEY M. ADAMS	SUMMER CONCERT SERIES - 7/1/2026 PERFORMANCE	200.00
63. JOEL MATTHEW KRUPA	2026 MERIDIAN PRIDE EVENT PERFORMER - TIME TRAVELIN	375.00
64. JOSEPH CESARIO	FARMERS MARKET VENDOR	30.00
65. KARLENE B. BELYEA	SUMMER CONCERT SERIES - SEPTEMBER 23, 2026 PERFORME	500.00
66. KATHARINE MERRITT	REFUND REQUEST FOR WDV #26-008 REQUEST- OWNER WITHD	1,885.00
67. KATHY FORD	SUMMER CONCERT SERIES - JULY 22, 2026 PERFORMER	150.00
68. KELLER THOMA	PROFESSIONAL SERVICES	690.00
	PROFESSIONAL SERVICES	57.50
	TOTAL	747.50
69. KEVIN THOMAS	FARMERS MARKET VENDOR	73.00
70. KIMBALL MIDWEST	MP - STOCK	664.91
	MP - PARTS	56.80
	TOTAL	721.71
71. KLEYN MOBILE REPAIR, LLC	MP - FIRE - ENGINE 92 - UNIT 150 - ENGINE OVERHUAL	32,074.09
72. LAFONTAINE CHRYSLER DODGE	JEEP RAM	
	MP - PARKS - 659	76.61
73. LAFONTAINE FORD OF LANSING	MOTOR POOL - VEHICLE REPAIR PARTS	53.76
	MP - POLICE - 716	807.76
	MP - PARKS - 76	170.01
	TOTAL	1,031.53
74. LANETTE HESTER	BAND LEAD FOR ELEMENTS OF SOUL JUNETEENTH 2026	1,500.00
	SUMMER CONCERT SERIES - 7/8/2026 PERFORMANCE	1,200.00
	TOTAL	2,700.00
75. LANSING SANITARY SUPPLY INC	CLEANING SUPPLIES (MOP CLEANER, LAUNDRY DETERGENT)	804.56
76. LATCHAW PRODUCTIONS	SUMMER CONCERT SERIES - JULY 29, 2026 PERFORMER	700.00
77. LAURIE DEBRUIN	2026 MERIDIAN PRIDE EVENT PERFORMER - SMOKEY BEAR B.	1,200.00
	SUMMER CONCERT SERIES - AUGUST 19, 2026 PERFORMER	1,000.00
	SUMMER CONCERT SERIES - SEPTEMBER 16, 2026 PERFORME	250.00
	TOTAL	2,450.00
78. LEAK PETROLEUM EQUIPMENT INC	MP - BI ANNUAL AIR COMPRESSOR SERVICE	425.48

Vendor Name	Description	Amount
79. LEXISNEXIS RISK DATA MGT LLC	POLICE ACCURINT QUERY SERVICE MAY 2026	200.00
80. LIGHT OF DAY CONSTRUCTION	**HAND CHECK TO BE MAILED PLEASE** REFERENCE CHILL	11,995.00
81. LISA A. WILSON	FARM MARKET VENDOR	298.00
82. LOPEZ CONCRETE CONSTRUCTION	CONCRETE SPOT REPAIR 2026	228,214.40
83. LUKE LANDSCAPE COMPANY	2026 RIVERSIDE CEMETERY CLEANUP & RETAINING WALL RE	9,996.06
84. MADISON NATIONAL LIFE INS CO	2026 LIFE/DISABILITY INSURANCE	4,569.69
85. MAGGIE BURCH	REIMBURSEMENT FOR PAVILION RENTAL SECURITY DEPOSIT	250.00
86. MANNY APPEL	AETNA REPROCESSED AND PAID	376.42
87. MARY J BOLLMAN	MMS CREDIT REFUND ACCT # 009393	273.92
88. MATTHEW COTTINGHAM	UMPIRE SCHEDULING SERVICES FOR MERIDIAN TOWNSHIP AT	700.00
89. MATTHEW D. PALMER	SUMMER CONCERT SERIES - JULY 22, 2026 PERFORMANCE	1,200.00
90. MEDICAL MANAGEMENT SYSTEMS	2026 COLLECTION FEE FROM AMBULANCE BILLINGS	9,742.64
91. MERIDIAN TOWNSHIP RETAINAGE	CONCRETE SPOT REPAIR 2026	5,087.60
	2026 LOCAL STREET MILLING AND RESURFACING CONTRACT	8,234.74
	2026 LOCAL STREET CRUSHING AND RESURFACING CONTRACT	17,898.33
	TOTAL	31,220.67
92. MICHELLE COX	REIMBURSEMENT FOR MAMC TRAVEL	122.23
93. MICHIGAN PAVING	2026 LOCAL STREET MILLING AND RESURFACING CONTRACT	67,012.66
94. MICHIGAN SEPTIC LLC	2026 - PUMP OUT PIT TOILETS AT HARRIS NATURE CENTER	400.00
95. MID MICHIGAN EMERGENCY EQUIPMENT	MP - POLICE - 750	135.00
96. MIKE KEREKES	FARMERS MARKET	8.00
97. MORRIES OKEMOS FORD	MP - POLICE - 661	260.40
	MP - POLICE - 695	604.76
	TOTAL	865.16
98. MY GREEN MICHIGAN LLC	COMPOST SERVICE AT MARKETPLACE JUNE 2026	177.00
99. NATIONAL WILDLIFE CONTROL	BUILDINGS - C. FIRE - PEST CONTROL	75.00
100. NAUGHTY GOAT FARM, LLC	FARMERS MARKET VENDOR	77.00
101. NICK HOEPFNER	2026 YOUTH SOCCER REF FEE 7 X 25	175.00
102. NOAH WHITNEY	PB25-1106 PERMIT REFUND REQUESTED FOR CANCELLED BU	80.00
103. OLMSTED FARMS	FARMERS MARKET VENDOR	539.00
104. ON DEMAND MOSQUITO MAN INC	2026 - MOSQUITO TREATMENTS FOR PARKS AND BUILDINGS/	1,535.00
105. OREILLY AUTO ENTERPRISES LLC	MP - POLICE - 721	89.64
106. PECULIAR COFFEE	FARMERS MARKET VENDOR	24.00
107. PIONEER MFG.CO/PIONEER ATHLETICS	BASEBALL FIELD CHALK AND REPLACEMENT PITCHING RUBBE	662.87
108. PIZZELLES PLUS	FARMERS MARKET VENDOR	92.00

Vendor Name	Description	Amount
109. PLM LAKE & LAND MANAGEMENT	2026 HERBICIDE TREATMENT CONTRACT FOR LAKE LANSING	45,292.50
110. PONDSIDE FARMS	FARMERS MARKET VENDOR	69.00
111. PORTER RYAN THOMPSON	2026 YOUTH SOCCER REF FEE 8 X 25	200.00
112. POSTMASTER	JULY LISTENING SESSION POSTCARD POSTAGE	1,195.10
113. PRO-COMM INC	PORTABLE RADIO REPAIR (S/N: 756CWK4369) & PICKUP/SH	735.00
114. PROGRESSIVE AE	2026 LAKE LANSING SAD PROFESSIONAL SERVICES CONTRAC	834.41
115. PRO-TECH MECHANICAL SERVICES	BUILDINGS - POLICE - REPAIRS TO THE CHECK VALVE IN	4,777.16
	BUILDINGS - 2026 HVAC SERVICES - PREVENTATIVE MAINT	4,206.25
	DEER MANAGEMENT COOLER - DISAGNOSTIC FOR REPAIRS	190.00
	BUILDINGS - MUNICIPAL - REPLACE COMPRESSOR ON AC UN	8,886.05
	TOTAL	18,059.46
116. PURITY CYLINDER GASES INC	MEDICAL OXYGEN & DELIVERY FEES	205.34
117. REDWOOD LANDSCAPING	WELCOME AND MUNI COMPLEX SIGN BED CLEANUP	280.00
118. RIETH-RILEY CONSTRUCTION CO INC	2026 LOCAL STREET CRUSHING AND RESURFACING CONTRACT	161,085.01
119. ROBINSON CAPITAL MANAGEMENT LLC	2026 INVESTMENT ADVISORY - ACCOUNT MANAGEMENT FEES	2,083.33
	2026 INVESTMENT ADVISORY - ACCOUNT MANAGEMENT FEES	2,083.33
	2026 INVESTMENT ADVISORY - ACCOUNT MANAGEMENT FEES	2,083.33
	TOTAL	6,249.99
120. RODNEY WOLFE	SUMMER CONCERT SERIES - AUGUST 5, 2026 PERFORMER	600.00
121. SARAH LAWRENCE	FARMERS MARKET VENDOR	20.00
122. SHAWN DIEMER	FARM MARKET VENDOR	547.00
123. SIMAR PAWAR	REIMBURSEMENT FOR MAMC TRAVEL	188.29
124. SPALDING DEDECKER ASSOCIATES	2025 LOCAL ROAD PROGRAM ENGINEERING & INSPECTION CO	1,752.00
	2026 LOCAL ROAD PROGRAM ENGINEERING & INSPECTION CO	63,249.25
	LRP BIOSWALE PROJECT - PHASE I PRELIMINARY INVESTIG	3,948.00
	2026 LOCAL ROAD PROGRAM ENGINEERING & INSPECTION CO	10,636.25
	2027 LOCAL ROAD PROGRAM ENGINEERING & INSPECTION CO	6,363.50
	HASLETT ROAD CORRIDOR STUDY - PHASE I	4,125.00
	TOTAL	90,074.00
125. SPARTAN FENCE	PATHWAY FENCE REPAIR ALONG OKEMOS ROAD NEAR WONCH P.	2,200.00
126. SPARTAN TURF PRODUCTS LLC	MP - PARKS - 689	167.45
127. ST MARTHA CONFERENCE OF	EMERGENCY RENTAL ASSISTANCE	500.00
	EMERGENCY RENTAL ASSISTANCE	500.00
	EMERGENCY RENTAL ASSISTANCE	800.00
	TOTAL	1,800.00
128. STARLIGHT FARMS INC	FARMERS MARKET	73.00
129. STATE FARM INSURANCE	MMS CREDIT REFUND ACCT # 009297 DARRYL A MIDDLETON	100.00
130. STATE TAX COMMISSION	MCAT CLASS AUGUST 2026 - REBEKAH KELLY	150.00

Vendor Name	Description	Amount
131. STEPHEN AUGUST CHAPKO II	SUMMER CONCERT SERIES - SEPTEMBER 30, 2026 PERFORME	500.00
132. STEPHEN GERHART JR	REIMBURSEMENT FOR MAMC TRAVEL	172.14
133. STONE CIRCLE BAKEHOUSE	FARMERS MARKET	145.00
134. STRYKER MEDICIAL	STRYKER STORE SUPPLIES (ELECTRODES, FILTERLINE, X-R	2,002.00
135. SUE MCMASTER	FARM MARKET VENDOR	49.00
136. SUPREME SANITATION	PORTABLE TOILETS FOR PARKS IN 2026	90.00
	PORTABLE TOILETS FOR PARKS IN 2026	180.00
	PORTABLE TOILETS FOR PARKS IN 2026	90.00
	PORTABLE TOILETS FOR PARKS IN 2026	90.00
	PORTABLE TOILETS FOR PARKS IN 2026	90.00
	PORTABLE TOILETS FOR PARKS IN 2026	180.00
	TOTAL	720.00
137. T MOBILE	04/21/22026 - 05/20/2026 CELLULAR 517.980.0920 9602	62.36
138. TARGET SOLUTIONS LEARNING LLC	POLICE TARGETSOLUTIONS FRONTLINE 3.31.2026-3.30.202	2,500.00
139. THE CHEESE PEOPLE OF GRAND RAPIDS	FARM MARKET VENDOR	119.00
140. THE HARKNESS LAW FIRM PLLC	PROSECUTING SERVICES CONTRACT 2026	8,151.06
141. THREE LAKES GARDEN	FARMERS MARKET VENDOR	156.00
142. TIM SCHMITT	MILEAGE REIMBURSEMENT - CRYSTAL MOUNTAIN	250.85
143. TITUS FARMS LLC	FARM MARKET VENDOR	1,401.00
144. TOP NOTCH TREE CARE	RED CEDAR WATER PROJECT MAY 2026	16,770.00
145. TURNIP THE BEETS FARM LLC	FARM MARKET VENDOR	84.00
146. UDDERLY MAGIC LLC	FARM MARKET VENDOR	39.00
147. VERIZON WIRELESS	2026 VERIZON WIRELESS MOBILE SERVICES 686304174-000	2,228.30
148. WARREN HAVAC SERVICE LLC	MECHANICAL PERMIT CANCELED AFTER ISSUANCE, 80% REFU	136.00
149. WEST SHORE SERVICES	SERVICE CALL FOR OUTDOOR WARNING SIREN (SITE 3, 399	450.00
150. WILDWOOD LAKES HOME OWNERS ASSOC.	2026 GREEN GRANT - WILDWOOD LAKES HOA	1,850.00
151. WILLIAM ANDREWS JR	SECURITY DEPOSIT REFUND - PARKS	100.00
152. YEO & YEO	ANNUAL AUDIT FYE 2025 FINAL BILLING / ASSISTANCE W .	18,975.00
TOTAL - ALL VENDORS		1,014,600.59

BANK CODE: PW53 - CHECK TYPE: PAPER CHECK

Vendor Name	Description	Amount
1. ALLGRAPHICS CORP	DPW LOGO WEAR	410.25
	2026 DPW LOGO WEAR - UNIFORMS	716.75
	TOTAL	1,127.00
2. APEX EXCAVATING & UNDERGROUND LLC	2026 FORCE MAIN PROJECT	94,115.50
3. ARCOSA SHORING PRODUCTIONS INC	COMPETENT PERSON TRAINING	1,000.00
4. BLACKBURN MFG CO	WATER BASED PAINT FOR MARKING WATER AND SEWER	779.60
5. CITY OF EAST LANSING	ELMWSA OPERATING, INTERCONNECT & DEBT SHARING JAN-J	418,914.58
	ELMWSA OPERATING, INTERCONNECT & DEBT SHARING JAN-J	418,914.58
	TOTAL	837,829.16
6. CUMMINS INC	GENERATOR MAINTNANCE 2026	871.60
	GENERATOR MAINTNANCE 2026	805.48
	GENERATOR MAINTNANCE 2026	714.60
	GENERATOR MAINTNANCE 2026	805.48
	TOTAL	3,197.16
7. E T MACKENZIE CO	2026 FOREST HILLS LIFT STATION AND WHITEHILLS LIFT	23,140.80
8. EJ USA INC	SEWER - 24" MANHOLE RISER RINGS	1,717.90
9. ELECTRICAL TERMINAL SERVICE	WATER - REPLACEMENT VALVE BOLTS	319.72
10. FERGUSON WATERWORKS #3386	WATER - WALL MOUNT R900S	3,252.27
	2026 AMI COLLECTOR INSTALLATIONS - PHASE II (5 COLL	37,121.72
	WATER - SUPPLIES	510.00
	TOTAL	40,883.99
11. HUAI ZHI CHEN & XIN XIN YAO	CONCRETE REIMBURSEMENT 2167 QUARRY ROAD	866.89
12. HYDROCORP	AUG 2024 TO AUG 2026 CROSS CONNECTION PROGRAM SERVI	2,735.00
13. JACK DOHENY COMPANIES INC	SEWER - QUICK CLAMPS FOR THE SEWER VACTOR	175.13
14. KIMBALL MIDWEST	WATER - STOCK	31.00
	WATER - STOCK	302.00
	TOTAL	333.00
15. LOPEZ CONCRETE CONSTRUCTION	CONCRETE SPOT REPAIR 2026	37,692.22
16. MADISON NATIONAL LIFE INS CO	2026 LIFE/DISABILITY INSURANCE	675.17
17. MASON, LAVERNE	UB Receipt Refund for Account #: WDWN-00	1,148.06
18. MERIDIAN TOWNSHIP RETAINAGE	2026 FORCE MAIN PROJECT	8,484.50
19. MICHIGAN PAVING	2026 LOCAL STREET MILLING AND RESURFACING CONTRACT	7,100.00
20. MIDWEST POWER EQUIPMENT	SURVERY SUPPLIES FOR TRUCK #128 - MEASURING WHEEL	19.99
21. OLGIER BROTHERS SAND & GRAVEL	WATER - SAND , GRAVEL & TOPSOIL 2026	1,209.60
22. SME	2025 MISCELLANEOUS TESTING CONTRACT	4,718.75
23. THORSON, ESTHER	UB refund for account: CIDE-002229-0000-	84.44

Vendor Name	Description	Amount
24. VERIZON WIRELESS	2026 VERIZON WIRELESS MOBILE SERVICES 686304174-000	450.00
TOTAL - ALL VENDORS		1,069,803.58

Vendor Name	Description	Amount
1. STATE OF MICHIGAN		
	2025 PILT PMT - MARSH POINTE APTS	23,634.06
	2025 PILT PMT - WOODWARD WAY	8,938.95
	TOTAL	<u>32,573.01</u>
TOTAL - ALL VENDORS		32,573.01

Transaction Date	Account Name	Transaction Amount	Transaction Merchant Name
2026/06/17	ROBERT STACY	\$123.90	SHERWIN-WILLIAMS701339
2026/06/23	ROBERT STACY	\$257.17	THE HOME DEPOT 2723
2026/06/23	ROBERT STACY	\$203.16	THE HOME DEPOT 2723
2026/06/29	ROBERT STACY	\$239.00	THE HOME DEPOT 2723
2026/06/12	TYLER KENNELL	\$25.22	THE HOME DEPOT #2723
2026/06/16	TYLER KENNELL	\$838.00	THE HOME DEPOT #2723
2026/06/21	MICHAEL HAMEL	\$45.90	AMAZON MKTPL*9Z6V04YH3
2026/06/22	MICHAEL HAMEL	\$45.86	ASAP PRINTING
2026/06/24	MICHAEL HAMEL	\$619.59	IN *PLASTIX PLUS
2026/06/24	MICHAEL HAMEL	\$83.29	THE UPS STORE 811
2026/06/15	KYLE FOGG	\$36.24	THE HOME DEPOT #2723
2026/06/23	KYLE FOGG	\$284.38	THE HOME DEPOT #2723
2026/06/29	KYLE FOGG	\$331.57	THE HOME DEPOT #2723
2026/06/17	RYAN CAMPBELL	\$41.51	THE HOME DEPOT #2723
2026/06/25	JACOB FLANNERY	\$86.91	THE HOME DEPOT 2723
2026/06/29	JACOB FLANNERY	\$64.98	THE HOME DEPOT #2723
2026/06/20	ASHLEY WINSTEAD	\$38.23	AMAZON MARK* 0002H5T03
2026/06/25	ASHLEY WINSTEAD	\$49.95	AMAZON MARK* CK96K1QO3
2026/06/24	ASHLEY WINSTEAD	(\$15.74)	AMAZON MARK* 0002H5T03
2026/06/30	ASHLEY WINSTEAD	\$358.75	MICHIGAN ASSESSORS ASSOCI
2026/06/30	ASHLEY WINSTEAD	\$24.69	AMAZON MKTPL*C945U2AG3
2026/06/16	BRIAN PENNELL	\$60.65	JIMMY JOHNS 9055
2026/06/18	BRIAN PENNELL	\$127.95	JONES & BARTLETT LEARNING
2026/06/22	BRIAN PENNELL	\$60.05	JIMMY JOHNS 9055
2026/06/12	COURTNEY WISINSKI	\$12.90	USPS PO 2569800864
2026/06/12	COURTNEY WISINSKI	\$27.98	MEIJER STORE #025
2026/06/13	COURTNEY WISINSKI	\$380.15	AMAZON MKTPL*1X9C35FX3
2026/06/12	COURTNEY WISINSKI	\$93.88	EPIC SPORTS
2026/06/16	COURTNEY WISINSKI	\$262.80	COSTCO WHSE#1277
2026/06/17	COURTNEY WISINSKI	\$119.99	CANVA* I04915-88948091
2026/06/17	COURTNEY WISINSKI	\$65.46	QUALITY DAIRY#31
2026/06/17	COURTNEY WISINSKI	\$5.18	QUALITY DAIRY#31
2026/06/26	COURTNEY WISINSKI	\$65.86	WAL-MART #2866
2026/06/28	COURTNEY WISINSKI	\$323.96	AMAZON MKTPL*KZ7JH4SG3
2026/06/30	COURTNEY WISINSKI	\$320.00	IN *CHIEF CART, INC.
2026/06/12	ANGELA DEMAS	\$48.80	AMAZON MARK* KC3MN88Q3
2026/06/15	ANGELA DEMAS	\$28.04	THE UNION
2026/06/17	ANGELA DEMAS	\$19.03	THE UNION
2026/06/16	ANGELA DEMAS	\$34.98	TST*MI608 - BURDICKS BAR
2026/06/17	ANGELA DEMAS	\$16.96	SQ *BELL'S BREWERY
2026/06/19	ANGELA DEMAS	\$854.60	RADISSON PLAZA HOTEL A
2026/06/19	ANGELA DEMAS	\$1,068.25	RADISSON PLAZA HOTEL A
2026/06/19	ANGELA DEMAS	\$15.85	THE UNION
2026/06/23	ANGELA DEMAS	\$49.49	JIMMY JOHNS 9055
2026/06/30	ANGELA DEMAS	\$59.45	T AND D CONEY GRILL
2026/06/24	JUSTIN C CAROEN	\$78.91	LAFONTAINE CDJR OKEMOS
2026/06/29	JUSTIN C CAROEN	\$229.99	HARBOR FREIGHT TOOLS3459
2026/06/12	ROBERT CARETTI	\$214.78	THE HOME DEPOT 2723
2026/06/29	SAMANTHA WEBER	\$23.16	MEIJER STORE #025
2026/06/19	STEPHEN GEBES	\$481.85	ZOOM.COM 888-799-9666
2026/06/23	STEPHEN GEBES	\$98.85	PST*CONNECTED SOLUTIONS
2026/06/12	RICHARD GRILLO	\$247.94	THE HOME DEPOT 2723
2026/06/14	RICHARD GRILLO	\$57.96	AMAZON MKTPL*QQ81M7SW3
2026/06/15	RICHARD GRILLO	\$24.99	USATODAY CO DIGITAL

2026/06/16	RICHARD GRILLO	\$129.98	MERTS SPECIALTY MEA
2026/06/16	RICHARD GRILLO	\$21.19	ADOBE INC
2026/06/17	RICHARD GRILLO	\$32.13	MERTS SPECIALTY MEA
2026/06/17	RICHARD GRILLO	\$32.40	GFS STORE #1901
2026/06/18	RICHARD GRILLO	\$103.22	MEIJER STORE #025
2026/06/18	RICHARD GRILLO	\$29.77	MEIJER STORE #025
2026/06/18	RICHARD GRILLO	\$63.61	GFS STORE #1901
2026/06/23	RICHARD GRILLO	\$30.64	TST* THE NEST
2026/06/23	RICHARD GRILLO	\$82.99	GOOGLE YOUTUBE TV
2026/06/23	RICHARD GRILLO	\$15.90	BC PIZZA OF BELLAIRE
2026/06/24	RICHARD GRILLO	\$18.01	TST*PEARLS NEW ORLEANS
2026/06/25	RICHARD GRILLO	\$54.24	MARATHON 201335
2026/06/29	RICHARD GRILLO	\$14.49	OFFICEMAX/OFFICEDEPT#3379
2026/06/30	RICHARD GRILLO	\$37.56	AMAZON MKTPL*JT1ZY4QC3
2026/07/01	YOUNES ISHRAIDI	\$227.61	ULINE *SHIP SUPPLIES
2026/06/17	KEITH HEWITT	\$63.18	THE HOME DEPOT #2723
2026/06/14	MICHELLE PRINZ	\$56.99	AMAZON MKTPL*A58PF3HH3
2026/06/15	MICHELLE PRINZ	\$19.99	USATODAY CO DIGITAL
2026/06/19	MICHELLE PRINZ	\$19.99	USATODAY CO DIGITAL
2026/06/19	MICHELLE PRINZ	\$24.99	USATODAY CO DIGITAL
2026/06/17	CATHERINE ADAMS	\$92.40	AMAZON MKTPL*CX8TS46Q3
2026/06/23	CATHERINE ADAMS	\$34.98	AMAZON MKTPL*LP0SS4083
2026/06/24	CATHERINE ADAMS	\$54.35	TOP HAT CRICKET FARM INC
2026/06/26	CATHERINE ADAMS	\$954.00	DOUGLAS INDUSTRIES
2026/06/28	CATHERINE ADAMS	\$251.68	AMAZON MKTPL*PD8LK7HO3
2026/06/12	ED BESONEN	\$495.00	MI STATE POLICE PMTS
2026/06/16	ED BESONEN	\$200.00	MI STATE POLICE PMTS
2026/06/18	ED BESONEN	\$200.00	MI STATE POLICE PMTS
2026/06/27	ED BESONEN	(\$440.75)	MOTOCARD BIKE
2026/06/26	ED BESONEN	\$265.00	A1 DETAILING & CUSTOMS
2026/06/26	ED BESONEN	\$440.75	MOTOCARD BIKE
2026/06/29	ED BESONEN	\$17.77	MEIJER STORE #025
2026/06/30	ED BESONEN	\$103.00	PAYPAL *PROTRAININC
2026/06/30	ED BESONEN	\$183.99	SP FIREFIGHTING TOOLS
2026/06/30	ED BESONEN	\$249.00	B2G, LLC* O #208257
2026/06/12	BART CRANE	\$32.99	COVERT SCOUTING
2026/06/17	BART CRANE	\$101.71	OFFICEMAX/OFFICEDEPT#3379
2026/06/18	BART CRANE	\$11.98	QUALITY DAIRY#31
2026/06/21	BART CRANE	\$227.01	AMAZON MKTPL*4L5R63RO3
2026/06/22	BART CRANE	\$16.96	SHANTY CREEK RESORT F AND
2026/06/23	BART CRANE	\$32.72	TST* SHORT'S BREWING COMP
2026/06/23	BART CRANE	\$11.93	TST* THE M-88 GRIND
2026/06/23	BART CRANE	\$15.90	BC PIZZA OF BELLAIRE
2026/06/23	BART CRANE	\$228.53	COMCAST / XFINITY
2026/06/24	BART CRANE	\$59.98	AMAZON MKTPL*BO5ZJ1EY3
2026/06/24	BART CRANE	\$25.46	TST* THE M-88 GRIND
2026/06/24	BART CRANE	\$71.65	SPEEDWAY 44470
2026/06/24	BART CRANE	\$13.55	WENDY S # 3632
2026/06/26	BART CRANE	\$100.00	PAYPAL *PAAM
2026/06/26	BART CRANE	\$50.00	MSU PAYMENT ONLINE
2026/06/17	DANIEL OPSOMMER	\$3,059.60	BRIMAR INDUSTRIES
2026/06/25	DANIEL OPSOMMER	\$376.25	TITANHQ
2026/06/16	ALLISON GOODMAN	\$13.97	WAL-MART #2866
2026/06/16	ALLISON GOODMAN	\$20.99	FEEDERS SUPPLY COMPANY #4
2026/06/22	ALLISON GOODMAN	\$56.67	MEIJER STORE #025

2026/06/17	ROBERT MACKENZIE	\$485.70	AMAZON RETA* 8F3HV1Z53
2026/06/18	ROBERT MACKENZIE	\$223.48	AMAZON MKTPL*EX7C60213
2026/06/18	ROBERT MACKENZIE	\$27.88	AMAZON MKTPL*QP6DX5OZ3
2026/06/18	CURT SQUIRES	\$465.75	AMAZON MKTPL*1251C3BN3
2026/06/23	CURT SQUIRES	\$55.20	FEDEX OFFICE 0406 LANKO
2026/06/23	CURT SQUIRES	\$210.00	SQ *CHER CAR KENNELS LLC
2026/06/12	SAMANTHA DIEHL	\$14.61	FACEBK *7QGSZQZ822
2026/06/18	SAMANTHA DIEHL	\$230.63	PENS.COM
2026/06/24	SAMANTHA DIEHL	\$64.98	VISTAPRINT
2026/06/24	SAMANTHA DIEHL	\$24.00	DOLLAR TREE
2026/06/30	SAMANTHA DIEHL	\$188.00	FILMFREEWAY
2026/06/15	THOMAS BAKER	\$27.48	THE HOME DEPOT #2723
2026/06/17	THOMAS BAKER	\$17.82	HASLETT TRUE VALUE HARDWA
2026/06/17	THOMAS BAKER	\$63.26	THE HOME DEPOT #2723
2026/06/22	THOMAS BAKER	\$8.96	THE HOME DEPOT #2723
2026/06/16	LAWRENCE BOBB	\$71.50	CATHEY CO
2026/06/22	LAWRENCE BOBB	\$44.61	THE HOME DEPOT #2723
2026/06/24	LAWRENCE BOBB	\$111.96	MIDWEST POWER EQUIPMENT
2026/06/23	LAWRENCE BOBB	\$47.64	THE HOME DEPOT #2723
2026/06/29	LAWRENCE BOBB	\$69.96	THE HOME DEPOT #2723
TOTAL		\$20,524.57	

ACH Transactions

6/12 to 7/2

<u>Date</u>	<u>Payee</u>	<u>Amount</u>	<u>Purpose</u>
6/25/2026	State of Michigan	\$ 21,574.83	6/26 Payroll Taxes
6/12/2026	Nationwide	\$ 11,926.27	6/12 Payroll Deductions
6/26/2026	Nationwide	\$ 12,568.33	6/26 Payroll Deductions
6/29/2026	EmPower	\$ 55,390.72	Employee Retirement
6/15/2026	EmPower	\$ 63,214.20	Employee Retirement
6/22/2026	Consumers Energy	\$ 64,931.37	Utility Transaction Fees
6/25/2026	MERS	\$ 1,085,190.62	Employee Retirement
6/17/2026	Blue Care Network	\$ 773.53	Employee Health Insurance
6/24/2026	Blue Care Network	\$ 109,900.75	Employee Health Insurance
7/1/2026	Blue Care Network	\$ 88,559.97	Employee Health Insurance
6/30/2026	EyeMed	\$ 2,312.01	Employee Vision Insurance
6/12/2026	MCT Utilities	\$ 190.36	Water/Sewer Utility Transactions
6/22/2026	MCT Utilities	\$ 2,231.60	Water/Sewer Utility Transactions
6/24/2026	IRS	\$ 140,862.18	6/26 Payroll Deductions
6/25/2026	Various Financial Institutions	\$ 396,110.37	6/26 Payroll Deductions
	Total ACH Payments	\$ 2,055,737.11	



To: Board Members
From: Stephen Gebes, IT Director
Date: July 1, 2026
Re: NASPO Contract Administrator Assignments

Meridian Township began using Verizon cellular data services in 2008. Since the onset of this partnership, the Township has purchased various offerings on GSA, MIDeal, and WSCA competitively bid contracts. Recently, we have found some services only available on and/or more competitively priced on the NASPO ValuePoint contract. Given this discovery, we are requesting to have our agreement with Verizon and NASPO reflect the contract administrator assignments specified in the attached letter.

As such, the following motion is presented for the Board's consideration:

MOVE TO AUTHORIZE THE TOWNSHIP SUPERVISOR TO SIGN THE ATTACHED LETTER ESTABLISHING NASPO VALUEPOINT CONTRACT ADMINISTRATORS FOR MERIDIAN CHARTER TOWNSHIP.

Attachment:

1. Assignment of Authorization to administer NASPO Valuepoint Contract
2. NASPO ValuePoint participating addendum, Master Agreement #: MA152



Meridian Township
5151 Marsh Road
Okemos, MI 48864

P 517.853.4000
F 517.853.4096

Township Board:

Scott Hendrickson
Township Supervisor

Angela Demas
Township Clerk

Linda Burghardt
Township Treasurer

Kathy Ann Sundland
Township Trustee

Marna Wilson
Township Trustee

Nickolas Lentz
Township Trustee

Peter Trezise
Township Trustee

Timothy H. Dempsey
Township Manager

July 9, 2026

To Whom It May Concern:

Meridian Charter Township is a "Participating Entity" with NASPO and will be obtaining Verizon "Network Slice" wireless (and other) services pursuant to NASPO ValuePoint Contract Requirements.

Listed below are the Township personnel authorized to manage municipal wireless services:

Kris Cole
Network Technician
Meridian Charter Township
5151 Marsh Road
Okemos, MI 48864
+1 517.853.4228 (voice)
+1 517.853.4251 (facsimile)
cole@meridian.mi.us

Omar Abulibdeh
Network Technician
Meridian Charter Township
5151 Marsh Road
Okemos, MI 48864
+1 517.853.4224 (voice)
+1 517.853.4251 (facsimile)
abulibdeh@meridian.mi.us

Stephen Gebes
Information Technology Director
Meridian Charter Township
5151 Marsh Road
Okemos, MI 48864
+1 517.853.4222 (voice)
+1 517.853.4251 (facsimile)
gebese@meridian.mi.us

Bernadette Blonde
Finance Director
Meridian Charter Township
5151 Marsh Road
Okemos, MI 48864
+1 517.853.4104 (voice)
+1 517.853.4251 (facsimile)
blonde@meridian.mi.us

Jessica Fajardo <fajardo@meridian.mi.us>
Bookkeeper
Meridian Charter Township
5151 Marsh Road
Okemos, MI 48864
+1 517.853.4116 (voice)
+1 517.853.4251 (facsimile)
fajardo@meridian.mi.us

Richard Grillo
Police Chief
Meridian Charter Township
5151 Marsh Road
Okemos, MI 48864
+1 517.853.4804 (voice)
+1 517.347.4285 (facsimile)
grillo@meridian.mi.us

Please don't hesitate to contact me if you need any clarification whatsoever.

Sincerely,

Scott Hendrickson
Meridian Township Supervisor
+1 517.853.4250
board@meridian.mi.us or hendrickson@meridian.mi.us



NASPO ValuePoint

PARTICIPATING ADDENDUM

WIRELESS, DATA, VOICE AND ACCESSORIES

Led by the state of Utah

Master Agreement #: MA152

Contractor: **CELLCO PARTNERSHIP, D/B/A VERIZON WIRELESS**

Participating Entity:

1. Scope: Verizon Wireless (“Contractor”) and the State of Utah, for itself and on behalf of the NASPO ValuePoint (“NASPO ValuePoint” and/or “Customer”), have entered into a Master Agreement #MA152 with an effective date of August 12, 2019, which together with any and all amendments and/or addenda thereto constitute the "Master Agreement". This Participating Addendum applies to the purchase and use of Products (e.g. wireless service, software and other services) by state agencies and other eligible entities authorized by a state’s statutes to purchase under state/entity contracts. All capitalized terms not defined in this Participating Addendum will have the same meaning provided in the Master Agreement.

2. Participation: Use of specific NASPO ValuePoint cooperative contracts by agencies, political subdivisions and other entities (including cooperatives and non-profits) authorized by an individual state’s statutes to use state/entity contracts may be subject to the acknowledgement of the respective State Chief Procurement Official. Issues of interpretation and eligibility for participation are solely within the authority of the State Chief Procurement Official. Pursuant to NASPO ValuePoint rules and policies, entities in those states without a State Participating Addendum to the Master Agreement are eligible to participate in the Master Agreement to the extent not prohibited by their state and local procurement laws and regulations. It will be the responsibility of the Purchasing Entity to comply with any legal or regulatory provisions applicable to the Purchasing Entity. By signing and entering into this Participating Addendum, the Participating Entity certifies that they have obtained all of the acknowledgements and approvals required by state or local law or regulation. Purchasing Entity will immediately notify Contractor of any change in its eligibility to purchase under this Participating Addendum. Contractor reserves the right to terminate this Participating Addendum if at any time it is determined that Purchasing Entity is not eligible to purchase under this Participating Addendum.

3. Purchase Order Instructions: All Purchase Orders and any other ordering documents under this Participating Addendum will be governed by the terms and conditions of this Participating Addendum and the Master Agreement including, without limitation, the obligation to pay Contractor for Products provided. Contractor and the Participating Entity (together the “Parties”) acknowledge and agree that orders submitted to Contractor from a Purchasing Entity through the Purchasing Entity’s Business Procurement Card are authorized Purchase Orders under the Master Agreement.

All Purchase Orders issued by Purchasing Entities under this Participating Addendum shall include a reference to this Participating Addendum and the Master Agreement, number MA152.

4. Individual Customer: Except to the extent modified by this Participating Addendum, the Participating Entity and each Purchasing Entity will be responsible for compliance with the terms and conditions of the Master Agreement, and will have the same rights and responsibilities for their



NASPO ValuePoint

PARTICIPATING ADDENDUM

WIRELESS, DATA, VOICE AND ACCESSORIES

Led by the state of Utah

purchases as the Lead State has in the Master Agreement, including the same rights to any indemnity or to recover any costs. Each Purchasing Entity will be responsible for its own taxes, charges, fees, and liabilities. The Contractor will apply the charges to each Purchasing Entity individually.

All Participating Entities and Purchasing Entities agree to the terms and conditions of the Master Agreement, and to the extent the Purchasing Entity purchases any Verizon's Smart Communities products, services and solutions, those purchases are governed by the supplemental terms set forth at <https://enterprise.verizon.com/solutions/public-sector/state-local/contracts/naspo/> (except to the extent modified by this Participating Addendum) including the disclosure of limited account information as part of the contractual reporting requirements to NASPO ValuePoint and/or the Participating Entity for purposes of monitoring the Master Agreement and this Participating Addendum, and calculating the administrative fees.

5. Primary Contacts: The primary contact individuals for this Participating Addendum are as follows (or their named successors):

Lead State

Name:	Brett Whitelaw, State Contract Analyst
Address:	4315 S. 2700 W FL 3, Taylorsville, UT 84129-2128
Telephone:	(801) 957-7149
Email:	bwhitelaw@utah.gov

Contractor

Name:	Brittanie Fleming, Program Manager
Address:	10170 Junction Dr., Annapolis Junction, MD, 20701
Telephone:	(240) 280-3414
Email:	brittanie.cooper@verizonwireless.com

Participating Entity

Entity Name:	
Address:	
City, State, Zip:	
Telephone:	
Email:	



NASPO ValuePoint

PARTICIPATING ADDENDUM

WIRELESS, DATA, VOICE AND ACCESSORIES

Led by the state of Utah

6. Entire Agreement: This Participating Addendum, and the Master Agreement (number MA152 administered by the State of Utah) together with its exhibits, set forth the entire agreement between the Parties regarding the subject matter contained herein, and supersedes any and all previous communications, representations or agreements, whether oral or written. Terms and conditions inconsistent with, contrary or in addition to the terms and conditions of this Participating Addendum and the Master Agreement, together with its exhibits, shall not be added to or incorporated into this Participating Addendum or the Master Agreement and its exhibits, by any subsequent purchase order or otherwise (except by duly-executed written amendment), and any such attempts to add or incorporate such terms and conditions are hereby rejected and shall be deemed null and void.

The undersigned represents and warrants that he/she has the power and authority to execute this Participating Addendum, bind the respective Participating Entity, and that the execution and performance of this Participating Addendum has been duly authorized by all necessary Parties

The Parties have executed this Participating Addendum as of the date of final execution below.

Participating Entity:	Contractor: Cellco Partnership d/b/a Verizon Wireless
Signature:	Signature:
Printed Name:	Printed Name: Clifton Miller, Jr.
Title:	Title: Sr. Dir - Contract Management
Date:	Date:

[Additional signatures may be added if required by the Participating Entity]



NASPO ValuePoint

PARTICIPATING ADDENDUM

WIRELESS, DATA, VOICE AND ACCESSORIES

Led by the state of Utah

For questions on the Participating Addendum or NASPO ValuePoint cooperative contracting process, please contact the NASPO ValuePoint Cooperative Contract Coordinator assigned to this Portfolio, as provided on this Portfolio's webpage at www.naspovaluepoint.org or the NASPO ValuePoint team at ccc@naspovaluepoint.org.

*****Attach Exhibit 1 if necessary – Participating Entity Modifications or Additions*****

Contractor - email a fully executed PDF copy of this document to:

PA@naspovaluepoint.org

***To support documentation of participation and posting
in appropriate databases***



To: Board Members
From: Amber Clark, Neighborhoods and Economic Development Director
Date: July 7, 2026
Re: Outdoor Gathering Permit & Special Liquor License Approval – Pins and Pints

Attached is a request from Pins and Pints (2120 Hospitality LLC), a local bowling alley and entertainment venue in Meridian Township, to host a car show in August at their business address of 2120 Saginaw Highway. This is the third time Pins and Pints has hosted an event of this type in the Township. The Fire, Community Planning, and Police Departments have reviewed their request and have no objections.

Event Details:

August 21, 2026 Pins and Pints will host a car show on the property. Bowling activities will also still be available to the public. Attendees of the car show will be seated in a safe viewing area separated from the cars. Beverages can only be purchased inside of Pins and Pints, or from available service staff during the event.

Time: 5:00 PM to 9:00 PM

It is the joint recommendation of the departments that the Township Board approve the Outdoor Assembly Permit and authorize the Temporary Authorization Application for alcoholic beverage sales at the August 21, 2026 event.

The following motion has been prepared for your consideration:

MOVE TO APPROVE THE OUTDOOR ASSEMBLY LICENSE FOR PINS AND PINTS ON AUGUST 21, 2026 AT 2120 SAGINAW HIGHWAY. APPROVE THE TEMPORAY AUTHORIZATION APPLICATION FOR ALCOHOLIC BEVERAGE SALES FOR THE SAME DAY.

Attachments:

1. Pins and Pints Outdoor Event Map
2. MLCC Temporary Authorization Application

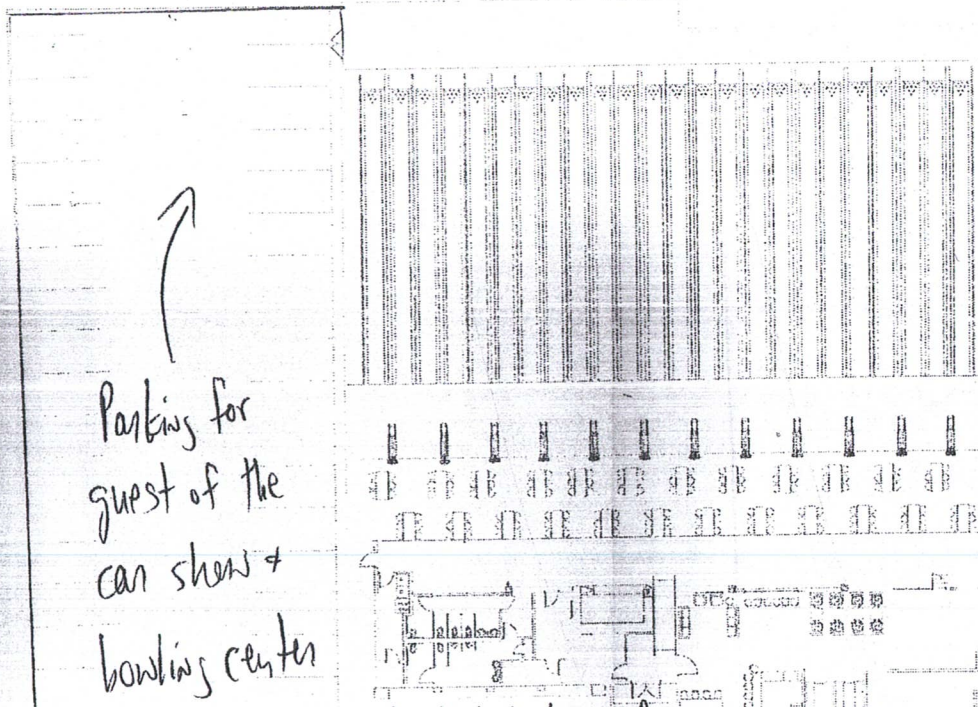

Parking for
guest of the
car show &
bowling center

* Alcohol to be sold
from inside the building
w/ servers taking
orders outside as well.

Patio

No vehicles past
this point other
than car show cars
Barricades or employee
cars parked to prevent access

Area for additional
out door tables for
eating if needed

96' W

All cars to use this drive

2120 E. Saginaw St., East Lansing, MI 48823

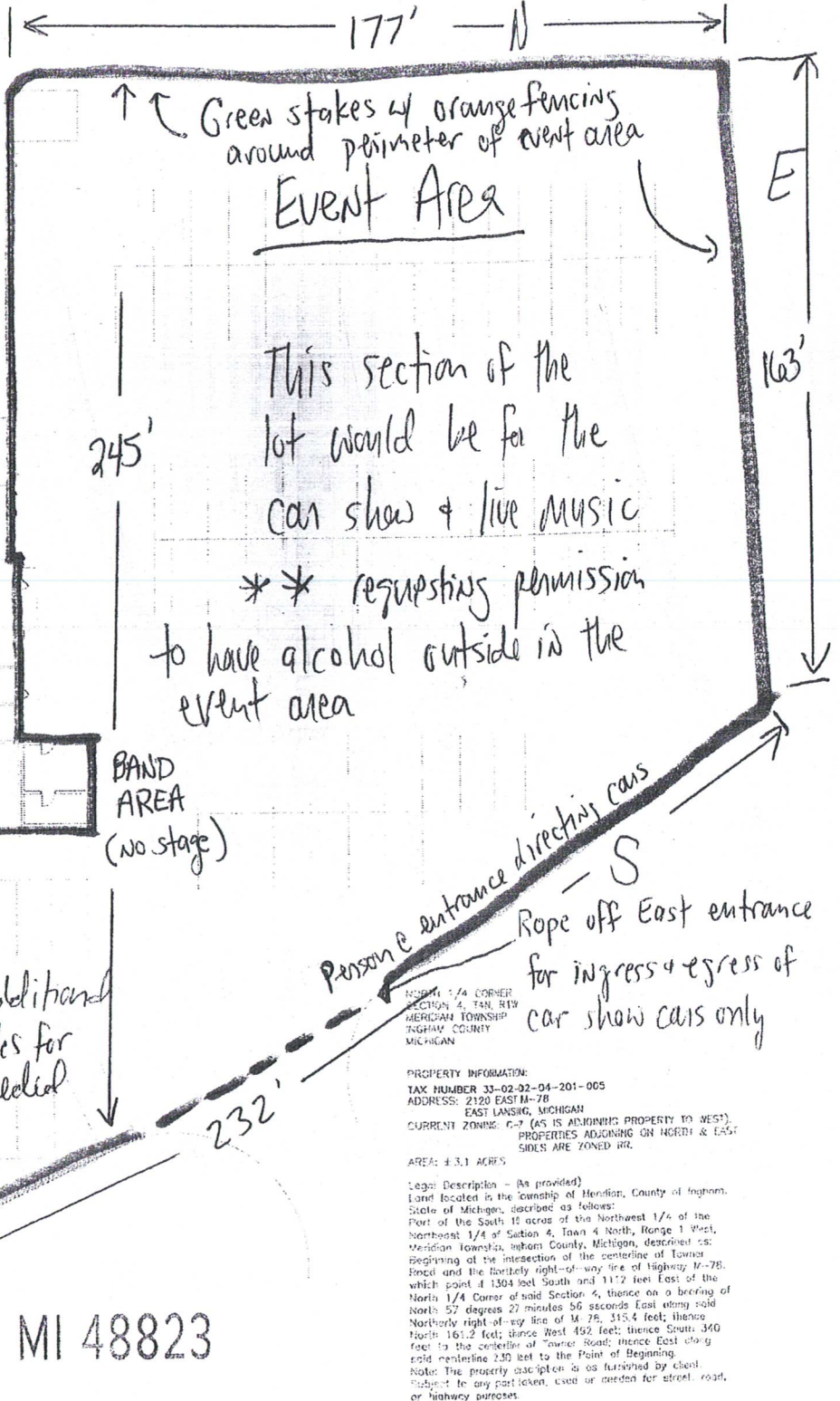

245'

Green stakes w/ orange fencing
around perimeter of event area
Event Area

This section of the
lot would be for the
car show & live music

** requesting permission
to have alcohol outside in the
event area

BAND
AREA
(no stage)

Personnel entrance directing cars
- S

Rope off East entrance
for ingress & egress of
car show cars only

Corner 1/4 Corner
SECTION 4, T4N, R17W
MERIDIAN TOWNSHIP
INGHAM COUNTY
MICHIGAN

PROPERTY INFORMATION:
TAX NUMBER 33-02-02-04-201-005
ADDRESS: 2120 EAST M-78
EAST LANSING, MICHIGAN
CURRENT ZONING C-7 (AS IS ADJOINING PROPERTY TO WEST).
PROPERTIES ADJOINING ON NORTH & EAST
SIDES ARE ZONED RR.

AREA: ± 3.1 ACRES.

Legal Description - (As provided)
Land located in the Township of Ingham, County of Ingham,
State of Michigan, described as follows:
Part of the South 1/2 acres of the Northwest 1/4 of the
Northwest 1/4 of Section 4, Town 4 North, Range 1 West,
Meridian Township, Ingham County, Michigan, described as:
Beginning at the intersection of the centerline of Towne
Road and the northerly right-of-way line of Highway M-78,
which point is 1304 feet South and 1172 feet East of the
North 1/4 Corner of said Section 4; thence on a bearing of
North 57 degrees 27 minutes 56 seconds East along said
Northerly right-of-way line of M 78, 315.4 feet; thence
North 165.2 feet; thence West 492 feet; thence South 340
feet to the centerline of Towne Road; thence East along
said centerline 230 feet to the Point of Beginning.
Note: The property description is as furnished by deed.
Subject to any part taken, used or needed for street, road,
or highway purposes.

232'

177'

163'

E

S



Temporary Authorization Application

(Authorized by R 436.1023(2),(3), R 436.1403(2), R 436.1407, and R 436.1419)

*****This application, all required documents, and a \$70.00 inspection fee must be submitted at least ten (10) days in advance of your event for your request to be considered by the Commission.*****

Part 1 - Licensee Information

Individuals, please state your legal name. Corporations or Limited Liability Companies, please state your name as it is filed with the State of Michigan Corporation Division.

Licensee name(s): 2120 Hospitality, LLC		
Address: 2120 E. Saginaw (site location)		927 E. Grand River E. Lansing (office)
City: E. Lansing	Zip Code:	
Contact name: Matt Hagan	Phone: 517-351-0765	Email: info@hrrentals.com

\$70.00 Inspection Fee - Make Check Payable to **State of Michigan** MLCC Use - Fee Code 4037

Part 2 - Temporary Authorizations Available

A licensee may request up to twelve (12) daily authorizations for each type of temporary authorization in a calendar year. A conditional licensee **is not** eligible for a temporary permit pursuant to MCL 436.1525(6). Select all that apply to this application:

<input checked="" type="checkbox"/> Temporary Outdoor Service Permit - Complete Parts 3, 8, and 9	<input type="checkbox"/> Temporary Extended Hours Permit - Complete Parts 6 and 9
<input type="checkbox"/> Temporary Dance Permit - Complete Parts 4 and 9	<input type="checkbox"/> Temporary Specific Purpose Permit - Complete Parts 7, 8, and 9
<input type="checkbox"/> Temporary Entertainment Permit - Complete Parts 5 and 9	

Part 3 - Temporary Outdoor Service Permit Information

A Temporary Outdoor Service Permit requires a recommendation from the local law enforcement agency that has primary jurisdiction over the licensed premises. **The local law enforcement agency must complete Part 8 of this application.**

Date(s) of event: 8-21-26	Describe event: classic car show from 5pm-9pm. We will also have a band playing for 2 to 3 hours in that time frame.	
Date(s) of event:	Describe event:	
Date(s) of event:	Describe event:	
1. Check below if the event(s) listed above will include any of the following:		
<input type="checkbox"/> Dancing <input type="checkbox"/> Contests <input type="checkbox"/> Tournaments <input checked="" type="checkbox"/> Classic Cars <input checked="" type="checkbox"/> Motorcycles <input checked="" type="checkbox"/> Concerts <input type="checkbox"/> Festivals		
2. List the exact dimensions of the proposed area: <u>232'</u> feet X <u>245'</u> feet = <u>56,840</u> square feet *Submit a diagram of the outdoor area with application*		
3. Describe type and height of the barrier that will be used to enclose the area: <u>metal stakes with 4' high orange fence. Along west side of the event area we'll have employee's cars parked as a barrier.</u>		
4. Will the proposed outdoor service area be connected to the licensed premises? <input checked="" type="radio"/> Yes <input type="radio"/> No		
If No, what is the distance from the licensed premises to the proposed area? _____ feet		
5. Is the entrance/exit point(s) for the proposed area through the licensed premises? <u>Have separate entrances</u> <input type="radio"/> Yes <input checked="" type="radio"/> No		
6. Are there any dedicated streets or intervening property between proposed area and the licensed premises? <input type="radio"/> Yes <input checked="" type="radio"/> No		
7. Describe type of security that will be used for event(s) and how it will be utilized to secure and monitor to prevent sales to minors and visibly intoxicated persons: <u>we will have cameras that cover the event area. Alcohol will only be available for purchase from inside or purchased through our servers. Most of our servers & management have taken the TIPS class. Servers & managers will monitor the event area.</u>		

Part 3 Continued - Temporary Outdoor Service Permit Information

8. Is the location of the proposed area owned, rented, or leased by the licensee?	<input checked="" type="radio"/> Yes <input type="radio"/> No
If No , submit a lease or written permission which grants the licensee the use of the proposed area. *Submit written permission from a city, township, or village if the proposed area is located on municipally-owned property*	
9. Is the proposed area located in the same local governmental unit as the licensed premises?	<input checked="" type="radio"/> Yes <input type="radio"/> No
If No , please explain:	
10. Does the licensee currently hold an Additional Bar Permit that will be utilized in the proposed area?	<input type="radio"/> Yes <input checked="" type="radio"/> No
If No , the licensee will be restricted to providing only table service in the proposed area unless a new Additional Bar Permit has been requested by the licensee and approved by the Commission. <i>This requirement applies only to Class C or B-Hotel licenses.</i>	

Part 4 - Temporary Dance Permit Information

<ul style="list-style-type: none">Licensees that currently hold a Dance Permit at the licensed premises do not need to request a Temporary Dance Permit for dancing in a Temporary Outdoor Service area.The dance floor must be at least 100 square feet, be clearly marked, and shall not have tables, chairs, or other obstacles on the dance floor while customers are dancing.
1. List the dates requested for a Temporary Dance Permit:

Part 5 - Temporary Entertainment Permit Information

<ul style="list-style-type: none">Licensees that currently hold a Entertainment Permit at the licensed premises do not need to request a Temporary Entertainment Permit for entertainment in a Temporary Outdoor Service area.A Temporary Entertainment Permit does not allow for topless activity on the licensed premises.	
1. List the dates requested for a Temporary Entertainment Permit:	
2. Describe the type of entertainment provided:	
3. Will the entertainment provided under the Temporary Entertainment Permit include a contest with prizes totalling over \$250.00 in retail value?	<input type="radio"/> Yes <input type="radio"/> No
If Yes , the licensee must complete Form LCC-207 and submit with this application. <i>No alcoholic beverages may be used as part of any contest or as a prize for a contest. No licensee may provide anything of value from another licensee without prior Commission approval.</i>	

Part 6 - Temporary Extended Hours Permit Information

<ul style="list-style-type: none">Licensees that currently hold an Extended Hours Permit in conjunction with a Dance or Entertainment Permit at the licensed premises do not need to request a Temporary Extended Hours Permit for use with a Temporary Outdoor Service area.
1. Select the permit type that requires a Temporary Extended Hours Permit*: <input type="checkbox"/> Dance Permit <input type="checkbox"/> Entertainment Permit
2. List the dates and hours requested for a Temporary Extended Hours Permit:

Part 7 - Temporary Specific Purpose Permit Information

<ul style="list-style-type: none">Licensees that currently hold a Specific Purpose Permit for an approved purpose at the licensed premises do not need to request a Temporary Specific Purpose Permit for the same purpose for use with a Temporary Outdoor Service Permit.A Temporary Specific Purpose Permit requires a recommendation from the local law enforcement agency that has primary jurisdiction over the licensed premises. The local law enforcement agency must complete Part 8 of this application.
1. Indicate the activity that requires extended hours* (e.g. food service):
2. List the dates and hours requested for a Temporary Specific Purpose Permit:

*Hours of Operation

Weekdays and Saturdays - Beer, wine, and spirits may be sold from 7:00 a.m. to 2:00 a.m. of the next day, provided that the sale of spirits is legal in the governmental unit where the license is desired.

Sundays - Legal hours of sale on Sundays are from 7:00 a.m. until 2:00 a.m. of the next day, provided the sale of alcoholic beverages on Sunday is legal in the governmental unit and the appropriate permit has been approved by the Commission and the permit has been issued.

Part 8 - Local Law Enforcement Recommendation for Temporary Outdoor Service Permit and Temporary Specific Purpose Permit
 The local law enforcement agency with primary jurisdiction over the event location must complete this section.

Name of law enforcement agency: <u>Meridian Township Police Department</u>	
Address of law enforcement agency: <u>5151 Marsh Rd Okemos Mi 48864</u>	
Phone number of officer: <u>(517) 853-4810</u>	Email of officer: <u>crane@meridian.mi.us</u>
I certify that I have reviewed this application and recommend the approval of the Temporary Outdoor Service Permit or Temporary Specific Purpose Permit by the Michigan Liquor Control Commission.	
<u>Bart Crane</u>	<u>B. Crane</u>
Print Name & Title of Reviewing Officer:	Signature of Reviewing Officer
	<u>06/29/26</u> Date

Part 9 - Signature of Licensee

If approved, the license shall not sell, or allow the consumption of alcoholic beverage outdoors, except in the defined area, under administrative rule R 436.1419.

If approved, the licensee shall provide service of alcoholic beverages in the outdoor area only by wait staff servicing the tables, unless the licensee uses an approved additional bar in the area where customers may obtain their alcoholic beverages from a bartender using a currently authorized additional bar or receiving approval by the Commission for a new Additional Bar Permit. This requirement applies only to Class C or B-Hotel licenses.

Refrigeration trucks and/or trailers cannot include an alcoholic beverage logo and must be rented by the licensee from a non-wholesale company. If the refrigeration truck/trailer allows customer access to obtain alcoholic beverages, an Additional Bar Permit must be obtained unless an existing Additional Bar Permit will be utilized.

Pursuant to MCL 436.1525(6), a conditional license must only include any existing permits and approvals held in connection with the seller's existing license. A conditional licensee **is not** eligible for a temporary permit pursuant to MCL 436.1525(6).

Under administrative rule R 436.1003, the licensee shall comply with all state and local building, plumbing, zoning, sanitation, and health laws, rules, and ordinances as determined by the state and local law enforcements officials who have jurisdiction over the licensee. Approval of this application by the Michigan Liquor Control Commission does not waive any of these requirements. The licensee must obtain all other required state and local licenses, permits, and approvals for this business before using this license for the sale of alcoholic liquor on the licensed premises.

I certify that the information contained in this form is true and accurate to the best of my knowledge and belief. I agree to comply with all requirements of the Michigan Liquor Control Code and Administrative Rules. I also understand that providing **false** or **fraudulent** information is a violation of the Liquor Control Code pursuant to MCL 436.2003.

Submit this application, all required documents, and a \$70.00 inspection fee at least ten (10) days in advance of your event for your request to be considered by the Commission. Make check payable to State of Michigan.

<u>Matt Hagan</u>	<u>Matt Hagan</u>	<u>6/17/26</u>
owner 21ao Hospitality LLC	Signature of Licensee	Date
Print Name of Licensee & Title		

Please return this completed form along with corresponding documents and fees to:
 Michigan Liquor Control Commission
 Mailing address: P.O. Box 30005, Lansing, MI 48909
 Hand deliveries or overnight packages: Constitution Hall - 525 W. Allegan, Lansing, MI 48933
 Fax to: 517-284-8557



LARA Revenue Services is not a part of
the Michigan Liquor Control
Commission (see note below).

Credit Card Authorization Form

**** FAX COMPLETED FORM TO SECURE FAX LINE: 517-284-8557 ****

**** DO NOT EMAIL OR MAIL THIS FORM ****

Requests with credit card payments that are not faxed to the above secure fax line will be destroyed along with the credit card authorization in order to ensure the security of applicants' personal credit card numbers.

****IF YOU ARE NOT SUBMITTING AN APPLICATION FORM WITH THIS CREDIT CARD AUTHORIZATION, YOU MUST PROVIDE AN ITEMIZATION OF THE FEES FOR WHICH YOU ARE SUBMITTING PAYMENT OR YOUR PAYMENT WILL NOT BE PROCESSED****

Name: _____
 Address: _____
 City: _____
 State: _____
 Zip Code: _____
 Phone: _____
 Applicant/Licensee Name: _____ Request or Business ID #: _____

Transaction Amount: _____
 Card Number: _____
 Check One:
 MasterCard Visa Discover
 Security Code/CW Code: _____
 Expiration Date: _____

Payment is for: _____

Signature _____

IF YOU ARE NOT SUBMITTING AN APPLICATION FORM WITH THIS CREDIT CARD AUTHORIZATION, YOU MUST PROVIDE AN ITEMIZATION OF THE FEES FOR WHICH YOU ARE SUBMITTING PAYMENT OR YOUR PAYMENT WILL NOT BE PROCESSED.

Credit Card Payment Itemization:

Fee Type	Fee Amount	MLCC Fee Code
<input type="checkbox"/> Inspection Fee(s):	_____	4036
<input type="checkbox"/> Special License Fee(s):	_____	4008
<input type="checkbox"/> Temporary Authorization Fee:	_____	4037
<input type="checkbox"/> License Renewal Fee(s):	_____	4004
<input type="checkbox"/> Manufacturer License(s):	_____	4038
<input type="checkbox"/> Wholesaler License(s):	_____	4085
<input type="checkbox"/> New Retailer License(s):	_____	4012
<input type="checkbox"/> Transfer Retailer License(s):	_____	4034
<input type="checkbox"/> Conditional License	_____	4012
<input type="checkbox"/> New Add Bar <input type="checkbox"/> Transfer Add Bar:	_____	4012/4034
<input type="checkbox"/> Sunday Sales Permit (AM):	_____	4033
<input type="checkbox"/> Sunday Sales Permit (PM):	_____	4032
<input type="checkbox"/> Catering Permit:	_____	4031

LARA Revenue Services is not a part of the Michigan Liquor Control Commission (MLCC). Receipt of payment and application forms by LARA Revenue Services does not constitute receipt of an application by the MLCC. **Applications submitted through LARA Revenue Services may take up to two (2) additional business days to be received by the MLCC after receipt by LARA Revenue Services.**

For requests that require a timely receipt of an application by the MLCC to be processed, such as Special Licenses and temporary requests, please ensure that your application will be received in adequate time to be processed by the MLCC after the payment is received and processed by LARA Revenue Services.



To: Township Board
From: Tim Dempsey, Township Manager
Date: June 30, 2026
Re: 2026 Board Meeting Schedule Update

I am requesting the Township Board hold a Special Meeting on July 21 at 5 p.m., before the Regular Meeting. The purpose of this meeting is to review the Board's current goals and discuss any revisions for 2027. This timing allows staff to align the 2027 budget with the Board's priorities. Since this meeting will be a work session format like last year, it will not be televised, but it will be open to the public.

MOTION TO APPROVE ADDING A SPECIAL MEETING TO THE 2026 BOARD MEETING SCHEDULE FOR JULY 21, 2026, AT 5:00 PM IN TOWN HALL OF THE MERIDIAN MUNICIPAL BUILDING, 5151 MARSH ROAD, OKEMOS, MICHIGAN, AND DIRECT THE CLERK TO PROVIDE THE NECESSARY PUBLIC NOTICES.



To: Board Members
From: Stephen Gebes, IT Director
Date: July 1, 2026
Re: Signature on Domain Controller purchase agreement with Brightline Technologies

Given recent forces on technology hardware pricing & delivery times, quotes for a physical network server were coming back in the \$20-30,000 range with lead times of eight weeks and more. Looking for a more effective alternative, the Technology Staff asked Brightline IT to provide the cheapest option possible that will meet our needs for the next twenty-four months. They proposed a refurbished HPE ProLiant server with a 36-month service contract for \$2,500. This was, by far, the best solution when compared to other available options.

As such, the following motion is presented for the Board's consideration:

MOVE TO AUTHORIZE THE TOWNSHIP SUPERVISOR TO SIGN THE ATTACHED AGREEMENT FOR PURCHASE OF A PRE-OWNED HPE PROLIANT SERVER.

Attachment:

1. Pre-Owned HPE ProLiant Server Quote # 006088



We have prepared a quote for you

Pre-Owned HPE ProLiant Server

Quote # 006088
Version 1

Prepared for:

Meridian Township

Stephen Gebes
geb@meridian.mi.us

Hardware & Software

Qty	Description	Price	Ext. Price
1	Pre-Owned Server Bundle	\$2,500.00	\$2,500.00
	Refurbished HPE ProLiant DL160 G10 Server <ul style="list-style-type: none"> • Intel Xeon Silver 4208 Processor • 32GB DDR4 2933 Memory • 2x 500W Power Supplies • HPE Smart Array SR Gen 10 Storage Controller • 4x 600GB 10K SAS HDDs 		
	Axiom Maintenance Services - 3 Year - 7x24, 4hr Response Time for HPE ProLiant DL160 G10 Server <ul style="list-style-type: none"> • Axiom Major Break-Fix Solutions • Axiom Cloud-Based Portal • Axiom Email, Phone, and Remote Support • Axiom On-Site Technical Assistance 		
1	Windows Server 2025 Standard - 16 Core License Pack (Perpetual)	\$1,176.00	\$1,176.00
		Subtotal:	\$3,676.00

Pre-Owned HPE ProLiant Server

Quote #006088 v1

Prepared For:
Meridian Township
 Stephen Gebes
 5151 Marsh Road
 Okemos, MI 48864
 P: (517) 853-4222
 E: gebes@meridian.mi.us

Prepared by:
Brightline Technologies
 James Cabalum
 10355 Citation Dr.
 Brighton, MI 48116
 P: (248) 886-0248
 E: James@brightlineit.com



Date Issued:
06.19.2026
 Expires:
07.06.2026

Quote Summary

Description	Amount
Hardware & Software	\$3,676.00
Total:	\$3,676.00

Payment Terms: NET 15

Please Note: Due to variability in distribution and supply-chain conditions, hardware pricing is only guaranteed for 24 hours.

Provider reserves the right to correct any errors, inaccuracies or omissions, and to change or update information or cancel orders if any information, including Services or pricing is inaccurate.

Acceptance and Incorporation by Reference

This Order together with the Master Services Agreement and Service Attachments and other terms and conditions identified on Exhibit A, all of which are incorporated herein by reference (collectively, the "Agreement") is between Brightline Technologies (sometimes referred to as "we," "us," "our," or "Provider"), and the customer identified on the Order (sometimes referred to as "you," "your," or "Client"). This Agreement is effective as of the date the Client accepts the Order (the "Effective Date").

By signing or accepting this Order, Client acknowledges, represents, and warrants that it has read and agrees to the terms and conditions identified on Exhibit A to this Order which are incorporated as if fully set forth herein.

The parties hereby agree that electronic signatures to this Order shall be relied upon and will bind them to the obligations stated herein. Each party hereby warrants and represents that it has the express authority to execute this Agreement(s).

Provider may make changes to the Agreement at any time. If there are changes, Provider will revise the date at the top of the document. Provider may or may not provide Client with additional notice regarding such changes. Client should review the terms and conditions regularly. Unless otherwise noted, the amended terms and conditions will be effective immediately, and your continued use of the Services thereafter constitutes your acceptance of the changes. If you do not agree to the amended terms and conditions, you must stop using the Services immediately. Please note, you may incur a termination fee or other third-party fees, if applicable.

The parties, acting through their authorized officers, hereby execute this Agreement.

Meridian Township

Signature: _____

Name: _____

Date: _____



Exhibit A

Agreement	Description
Master Services Agreement	General terms and conditions applicable to all Provider products and services.
Service Attachment for Managed Services	Core managed services including monitoring, remote management, and help-desk.
Service Attachment for Managed Compliance Services	Consulting and advising regarding regulatory and legal compliance.
Service Attachment for Co-Managed Services	Describes the division of responsibilities in a Co-managed environment.
Service Attachment for Penetration Testing	Penetration testing and simulating cyberattacks to identify and address vulnerabilities within an organization's systems, networks, and applications.
Service Attachment for Colocation	Responsibility matrix for organizations not using Provider's fully managed services.
Schedule of Services	Description of managed services offered by Provider.
Data Processing Agreement	Data security and privacy agreement including statutorily required terms.
Service Level Objectives	Targeted response times by tier of severity.
Schedule of Third-Party Services	Notice of third-party services and waiver of claims.



To: Township Board

**From: Timothy R. Schmitt, AICP
Director of Community Planning and Development**

Date: June 29, 2026

**Re: Text Amendment #2026-05 - Chicken Ordinance Updates -
RECONSIDERATION**

At the June 16, 2026 meeting, the Township Board approved Text Amendment 2026-05 to amend the districts in which backyard chickens were permitted to include nearly every place a single-family home could be built. This was a direct response to a homeowner request and it has already been well received in the community.

Since adoption, Staff has already had several homeowners come in and apply for backyard chickens under the new ordinance. One homeowner, however, applied for and began construction on their chicken coop, without realizing they are in the RN, Village of Nemoka Mixed Residential District, which was not included in the update. The RN district is only located in the area between Lake Lansing, Marsh Road, Haslett Road, and Lake Lansing Park South and is designed to allow flexibility in use, since this area has some of the older structures in the Township and there are small apartment buildings right next to single family homes. Staff contacted the resident within hours of discovering the issue, but substantial work had already been done. After talking to the resident, Staff began researching options to assist the homeowner.

The ordinance currently limits backyard chickens to only single-family homes and only within the existing single-family districts. The RN district allows for single-family home construction, so it could be added to the backyard chicken ordinance and still meet the intent of the ordinance. In talking to the Township Attorney's office, the easiest way to do this, since the ordinance has not been published for adoption yet, would be to reconsider the approval from the June 16, 2026 meeting. Should the Board reconsider the previous approval, the Board could then direct Staff to publish the amended ordinance, including the RN district. This would be amending the Planning Commission's recommendation, something the Board can do without sending the ordinance back for further discussion. Staff has prepared the following motions, should the Board choose to move forward with this action.

Move to reconsider the resolution to approve Text Amendment #2026-05 to amend the Code of Ordinances of the Charter Township of Meridian at Section 86-368 to update the standards for the keeping of backyard chickens and rabbits in the Township.

The secondary motion would be then be:

Move to adopt the amended resolution approving for reintroduction Text Amendment #2026-05 to amend the Code of Ordinances of the Charter Township of Meridian at Section 86-368 to update the standards for the keeping of

backyard chickens and rabbits in the Township, adding the RN, Village of Nemoke District to the list of districts where backyard chickens and rabbits are permitted.

Staff looks forward to the further opportunity to discuss this matter with the Board and potentially make further changes to this popular ordinance.

Attachments

1. Resolution to approve for Reintroduction Ordinance 2026-05
2. Ordinance 2026-05 – Chicken Ordinance Updates - REVISED

RESOLUTION TO APPROVE - Reintroduction

**Text Amendment #2026-05
Backyard Chicken and Rabbits Update**

RESOLUTION

At a regular meeting of the Township Board of the Charter Township of Meridian, Ingham County, Michigan, held at the Meridian Municipal Building, in said Township on the 7th day of July, 2026, at 6:00 p.m., Local Time.

PRESENT: _____

ABSENT: _____

The following resolution was offered by _____ and supported by _____.

WHEREAS, Backyard chickens and rabbits are regulated under Sec. 86-368(a)(8) in the Township zoning ordinance; and

WHEREAS, the Township Board asked the Planning Commission to review Sec. 86-368(a)(8) for the possibility of adding the RB and RX zoning districts to the list of single-family zoning districts that are enabled to have backyard chickens and rabbits and generally review the standards in the ordinance for any necessary updates; and

WHEREAS, the Planning Commission discussed the matter at their regular meeting on January 26, 2026 and February 9, 2026, held a public hearing for the updates at their regular meeting on April 13, 2026, and recommended changes to the ordinance at their April 27, 2026 meeting; and

WHEREAS, the Planning Commission has recommended that the areas where backyard chickens or rabbits can be located be expanded to include all single-family residential districts, and allowances be added for newly born chickens and rabbits; and

WHEREAS, the Township Board reviewed the proposal at their May 7, 2026 meeting and raised no major concerns, directing Staff to bring the ordinance back for introduction;

WHEREAS, the Township Board initially adopted the ordinance at their June 16, 2026 meeting;

WHEREAS, subsequently, Staff has run into a situation where consideration of adding the RN, Village of Nemoka Mixed Residential District, should be considered, as it is the only other area in the Township that widely allows single-family residential homes;

NOW THEREFORE, BE IT RESOLVED THE TOWNSHIP BOARD OF THE CHARTER TOWNSHIP OF MERIDIAN hereby REINTRODUCES FOR PUBLICATION AND SUBSEQUENT ADOPTION Ordinance No. 2026-05, entitled "An Ordinance to Update the Standards for the Regulation of Chickens and Rabbits in Single-Family Residential Districts", as amended to include

the RN, Village of Nemoka Mixed Residential District to the areas permitted for backyard chickens and rabbits, and

BE IT FURTHER RESOLVED that the Clerk of the Charter Township of Meridian is directed to publish the Ordinance in the form in which it is introduced at least once prior to the next regular meeting of the Township Board.

ADOPTED: YEAS: _____

NAYS: _____

STATE OF MICHIGAN)

) ss

COUNTY OF INGHAM)

I, the undersigned, the duly qualified and acting Clerk of the Township Board of the Charter Township of Meridian, Ingham County, Michigan, DO HEREBY CERTIFY that the foregoing is a true and complete copy of a resolution adopted at a regular meeting of the Township Board on the 7th day of July, 2026.

Angela Demas
Township Clerk

1
2
3
4
5
6
7
8
9
10
11
12
13
14
15
16
17
18
19
20
21
22
23
24
25
26
27
28
29
30
31
32
33
34
35
36
37
38
39
40
41
42
43
44
45
46
47
48
49

ORDINANCE NO. 2026-05

AN ORDINANCE TO AMEND THE ZONING ORDINANCE OF THE CHARTER TOWNSHIP OF
MERIDIAN AT ARTICLE IV, DISTRICT REGULATIONS, TO UPDATE THE STANDARDS FOR THE
REGULATION OF CHICKENS AND RABBITS IN SINGLE-FAMILY RESIDENTIAL DISTRICTS

THE CHARTER TOWNSHIP OF MERIDIAN ORDAINS:

Section 1. Section 86-368(b)(8), RR District: One-Family Rural Residential District, is hereby amended to read as follows:

Raising and keeping of chickens and rabbits as nonagricultural use. Male chickens, also known as roosters, are permitted by right only on parcels exceeding five (5) total acres. Roosters are not permitted on parcels within the Urban Services Boundary.

The raising and keeping of chickens and rabbits accessory only to one-family dwellings in the RAAA, RAA, RA, RB, RX and RN zoning districts is subject to the following requirements:

a. Registration.

1. Prior to the raising and keeping of chickens and rabbits on any property under this section, the property shall be registered with the Department of Community Planning and Development.
2. Only an individual living in a dwelling on the property shall raise or keep chickens and rabbits on the property. A registration may not be transferred.
3. Notwithstanding registering with the Township, private restrictions on the use of property shall remain enforceable and take precedence over the registration. Private restrictions include, but are not limited to, deed restrictions, condominium master deed restrictions, neighborhood association bylaws, and covenant deeds. The interpretation and enforcement of the private restriction is the sole responsibility of the private parties involved.

b. Standards. In addition to registering with the Township, the raising and keeping of chickens and rabbits accessory only to one-family dwellings in the RAAA, RAA, RA, RB, RX and RN zoning districts shall comply with the following standards:

1. In no case shall the maximum number of chickens and rabbits in any combination exceed four. Only chickens of egg laying age and/or rabbits older than three months shall apply to this ordinance.
2. Roosters shall not be allowed.
3. The sale of chickens, rabbits and eggs on the property is prohibited.
4. Chickens and rabbits shall not be kept in any location on the property other than in the rear yard as defined by the zoning ordinance.
5. Chickens and rabbits shall be provided with a covered structure and must be kept in the covered structure or an adjoining fenced area at all times. Covered structures and fenced areas used for the raising and keeping of chickens and rabbits are subject to all provisions of Chapter **86** (zoning), except the covered structure and fenced area shall be set back a minimum of 10 feet from a side or rear lot line and structures propose for reverse

1
2
3
4
5
6
7
8
9
10
11
12
13
14
15
16
17
18
19
20
21
22
23
24
25
26
27
28
29
30
31
32
33
34
35
36
37
38
39

frontage lots shall be located no closer than 30 feet to the right-of-way of the designated rear yard.

- 6. All structures for the raising and keeping of chickens and rabbits shall be constructed so as to prevent rodents or other animals from being harbored underneath, within, or within the walls of the structure.
- 7. All feed and other items associated with the raising and keeping of chickens and rabbits shall be kept in containers or otherwise protected so as to prevent access to or contact with rodents or other animals.
- 8. The covered structure used to house the chickens and rabbits and any fenced area shall be kept in a sanitary condition.
- 9. This section shall not regulate the keeping of chickens in those areas zoned RR (Rural Residential) or AG (Agricultural) where the raising of chickens is a permitted use when conducted in compliance with the Michigan Right to Farm Act and the generally accepted agricultural and management practices promulgated therein.

Section 2. Validity and Severability. The provisions of this Ordinance are severable and the invalidity of any phrase, clause or part of this Ordinance shall not affect the validity or effectiveness of the remainder of the Ordinance.

Section 3. Repealer Clause. All ordinances or parts of ordinances in conflict therewith are hereby repealed only to the extent necessary to give this Ordinance full force and effect.

Section 4. Savings Clause. This Ordinance does not affect rights and duties matured, penalties that were incurred, and proceedings that were begun, before its effective date.

Section 5. Effective Date. This Ordinance shall be effective seven (7) days after its publication or upon such later date as may be required under Section 402 of the Michigan Zoning Enabling Act (MCL 125.3402) after filing of a notice of intent to file a petition for a referendum.

ADOPTED by the Charter Township of Meridian Board at its regular meeting this **XXth** day of **XXXXXXX**, 2026.

Scott Hendrickson, Township Supervisor

Angela Demas, Township Clerk



To: Board Members

**From: Dan Opsommer, Deputy Township Manager
Director of Public Works & Engineering**

**Younes Ishraidi, Township Engineer
Deputy Director of Public Works & Engineering**

Date: July 1, 2026

**Re: Sanctuary #2 Public Streetlighting Improvement Special Assessment District
#430 - Resolution #4**

A request was received from the property owners of Sanctuary #2 for maintenance of streetlights within the Sanctuary #2 plat. The developer of the Sanctuary #2 plat paid Consumers Energy to install four (4) 47-watt LED streetlights with Traditional fixtures with cut-off, and standard fiberglass poles along Fresno Lane. This streetlight special assessment district (SAD) will fund the ongoing maintenance and electrical service cost of the streetlights.

The proposed first year cost for streetlighting in Sanctuary #2 is \$1,457.76 (\$208.25/lot) and the cost annually thereafter will be \$728.88 (\$104.13/lot) (subject to annual adjustments).

At its March 3, 2026 meeting, the Township Board held the first of two public hearings to hear objections to the improvement, cost estimate, and assessment district. The Township Board also adopted resolution #3.

This evening we are bringing resolution #4 to the Board to set the second and final public hearing for August 18, 2026.

Proposed Motion:

MOVE TO APPROVE THE SANCTUARY #2 PUBLIC STREETLIGHTING IMPROVEMENT SPECIAL ASSESSMENT DISTRICT #430 - RESOLUTION #4, WHICH FILES THE PROPOSED SPECIAL ASSESSMENT ROLL WITH THE OFFICE OF THE TOWNSHIP CLERK AND SETS THE DATE FOR A PUBLIC HEARING ON TUESDAY, AUGUST 18, 2026.

Attachments:

1. Resolution #4
2. Proposed Assessment Roll
3. Authorization for change in standard lighting contract form 547
4. Prints

**SANCTUARY #2 PUBLIC STREETLIGHTING IMPROVEMENT
SPECIAL ASSESSMENT DISTRICT NO. 430**

RESOLUTION NO. 4

At a regular meeting of the Township Board of the Charter Township of Meridian, Ingham County, held at the Meridian Township Municipal Building, 5151 Marsh Road, Okemos, MI 48864-1198, Phone (517) 853-4000, on Tuesday, July 7, 2026, at 6:00 p.m.

PRESENT: _____

ABSENT: _____

The following resolution was offered by _____
and supported by _____.

WHEREAS, by resolution adopted March 3, 2026, the Township Board of the Charter Township of Meridian, determined to operate and maintain four (4) 47-watt LED streetlights with Traditional fixtures with cut-off, and standard fiberglass poles along Crane Circle and assess the cost thereof to the property deemed benefited by said improvements, all in accordance with Act 188, Public Acts of Michigan, 1954, as amended; and

WHEREAS, the Supervisor has prepared and reported to the Township Board a special assessment roll assessing the cost of said improvements to the properties benefited thereby with the proper certificate attached thereto.

NOW, THEREFORE, BE IT RESOLVED BY THE TOWNSHIP BOARD OF THE CHARTER TOWNSHIP OF MERIDIAN, INGHAM COUNTY, MICHIGAN, AS FOLLOWS:

1. The plans showing the improvement and location thereof and an estimate of the cost thereof be filed with the Township Clerk and be available for public examination during regular working hours on regular working days.
2. Said special assessment roll shall be filed with the Office of the Township Clerk and shall be available for public examination during regular working hours on regular working days.
3. The Township Board shall meet at 6:00 p.m. on Tuesday, August 18, 2026, at the Meridian Township Municipal Building, 5151 Marsh Road, Okemos, Michigan, in the Charter Township of Meridian, for the purpose of reviewing and hearing objections to the special assessment roll.
4. The Township Clerk shall cause notice of such hearing and the filing of the assessment roll to be published twice in a newspaper of general circulation in the Township, prior to the date of the hearing. The first publication shall be at least ten (10) days before the hearing pursuant to Act 162, Public Acts of 1962. The Clerk shall also cause notice of such hearing to be mailed by first class mail to all property owners in the special assessment district shown on the current assessment rolls of the Township, at least ten (10) full days before the date of said hearing. Said notice as published and mailed shall be in substantially the following form: (SEE ATTACHED)

5. All resolutions and parts of resolutions insofar as they conflict with the provisions of this resolution be and the same are hereby rescinded.

ADOPTED:

YEAS: _____

NAYS: _____

Resolution declared adopted.

STATE OF MICHIGAN)

) ss.

COUNTY OF INGHAM)

I, the undersigned, the duly qualified and acting Clerk of the Charter Township of Meridian, Ingham County, **DO HEREBY CERTIFY** that the foregoing is a true and complete copy of proceedings taken by the Township Board at a regular meeting held on Tuesday, July 7, 2026.

Angela Demas, Township Clerk

**SANCTUARY #2 PUBLIC STREETLIGHTING IMPROVEMENT
SPECIAL ASSESSMENT DISTRICT NO. 430**

NOTICE OF HEARING

**TO THE RECORD OWNERS OF, OR PARTIES IN INTEREST IN, THE FOLLOWING PROPERTY
CONSTITUTING THE PROPOSED SPECIAL ASSESSMENT DISTRICT:**

Lots 1 through Lot 7 (inclusive), Sanctuary #2

PLEASE TAKE NOTICE that a special assessment roll for the Sanctuary #2 Public Streetlighting Improvement Special Assessment District #430 has been prepared and is on file in the Office of the Township Clerk for public examination.

Said special assessment roll has been prepared for the purpose of assessing the cost of the above described public improvements to the property benefited therefrom. All questions and/or concerns should be directed to Meridian Township Department of Public Works & Engineering at (517) 853-4440.

TAKE FURTHER NOTICE that the Township Board will meet on **Tuesday, August 18, 2026, at 6:00 p.m.** at the Meridian Township Municipal Building, 5151 Marsh Road, Okemos, MI 48864-1198, for the purpose of reviewing said special assessment roll and hearing objections thereto.

An owner or party in interest, or his or her agent, may appear in person at the hearing to protest the special assessment, or shall be permitted to file his or her appearance or protest by letter with the Township Clerk before the close of this hearing, and his or her personal appearance is not required. The owner or any person having an interest in the real property who protests in person or in writing at the hearing may file a written appeal of the special assessment with the Michigan Tax Tribunal within 30 days after the confirmation of the special assessment roll.

**"FOR PURPOSES OF THIS HEARING, THE AMOUNT TO BE ASSESSED AGAINST YOUR PROPERTY
IS ESTIMATED TO BE: First Year Cost: \$208.25/Lot
 Annual Thereafter: \$104.13/Lot**

Dated: _____

Angela Demas, Township Clerk
CHARTER TOWNSHIP OF MERIDIAN

**SANCTUARY #2 PUBLIC STREETLIGHTIN IMPROVEMENT
SPECIAL ASSESSMENT DISTRICT NO. 430**

ASSESSMENT ROLL

Lot 1 through 7 (inclusive), Sanctuary #2.

Legal Description/ Address	Property Owner & Address	First Year Cost	Annually Thereafter
33-02-02-32-427-008 (Lot 1) 3720 Crane Circle	James Giguere 3720 Crane Circle Okemos, MI 48864	\$208.25	\$104.13
33-02-02-32-427-007 (Lot 2) 3726 Crane Circle	James Giguere 3726 Crane Circle Okemos, MI 48864	\$208.25	\$104.13
33-02-02-32-427-006 (Lot 3) 3732 Crane Circle	James Giguere 3732 Crane Circle Okemos, MI 48864	\$208.25	\$104.13
33-02-02-32-427-005 (Lot 4) 3738 Crane Circle	James Giguere 3738 Crane Circle Okemos, MI 48864	\$208.25	\$104.13
33-02-02-32-427-004 (Lot 5) 3735 Crane Circle	James Giguere 3735 Crane Circle Okemos, MI 48864	\$208.25	\$104.13
33-02-02-32-427-003 (Lot 6) 3729 Crane Circle	James Giguere 3729 Crane Circle Okemos, MI 48864	\$208.25	\$104.13
33-02-02-32-427-002 (Lot 7) 3725 Crane Circle	Dondapati, Kiran & Tejaswi Kakarla 2628 Morning Glory Drive Okemos, MI 48864	\$208.25	\$104.13

(Subject to annual increases)



**AUTHORIZATION FOR CHANGE IN STANDARD LIGHTING
CONTRACT(COMPANY-OWNED) FORM 547**

Contract Number: 103025042856

Consumers Energy Company is authorized as of _____ by the Township of MERIDIAN, to make changes, as listed below, in the lighting system(s) covered by the existing Standard Lighting Contract between the Company and the Township of MERIDIAN, dated 1/6/2016.

Lighting Type: General Unmetered Light Emitting Diode Lighting Rate GU-LED

Except for the changes in the lighting system(s) as herein authorized, all provisions of the aforesaid Standard Lighting Contract dated 1/6/2016 shall remain in full force and effect.

Notification Number(s): 1063687363

Comments:

Township of MERIDIAN

By: _____

(Signature)

(Printed)

Its: _____

(Title)

This Agreement may be executed and delivered in counterparts, including by a facsimile or an electronic transmission thereof, each of which shall be deemed an original. Any document generated by the parties with respect to this Agreement, including this Agreement, may be imaged and stored electronically and introduced as evidence in any proceeding as if original business records. Neither party will object to the admissibility of such images as evidence in any proceeding on account of having been stored electronically.

RESOLUTION

RESOLVED, that it is hereby deemed advisable to authorize Consumers Energy Company to make changes in the lighting service as provided in the Standard Lighting Contract between the Company and the Township of MERIDIAN, dated 1/6/2016, in accordance with the Authorization for Change in Standard Lighting Contract dated _____,

heretofore submitted to and considered by this commission council board; and

RESOLVED, further, that the _____ Clerk be and are authorized to execute such authorization for change on the behalf of the Township.

STATE OF MICHIGAN
COUNTY OF INGHAM

I, _____, clerk of the Township of MERIDIAN do hereby certify that the foregoing resolution was duly adopted by the

commission council board of said municipality, at the meeting held on _____.

Dated:

Municipal Customer Type: Township

GENERAL UNMETERED LIGHT EMITTING DIODE LIGHTING RATE GU-LED

- (4) 46 watt LED Post Top Traditional to Install at location junco dr b/w lots 1 & corner
junco dr b/w lots 2 & 3
junco dr b/w lots 4 & 5
junco dr b/w lots 6 & 7;

SANCTUARY PH.3

Meridian Township, Ingham County, Michigan

MISS DIG System, Inc.
1-800-482-7171

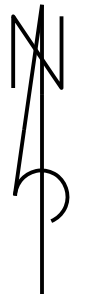

HULETT
LOON
JOLLY

Joint Work Contacts	Company Name	Contact Name	Phone Number	Reference # (NJUNS, UT # verbal, Etc.)	with ? Y/N
Phone					
CATV	COMCAST	DAN CRUSINBERRY		VERBAL	Y
Foreign Gas					
Other					

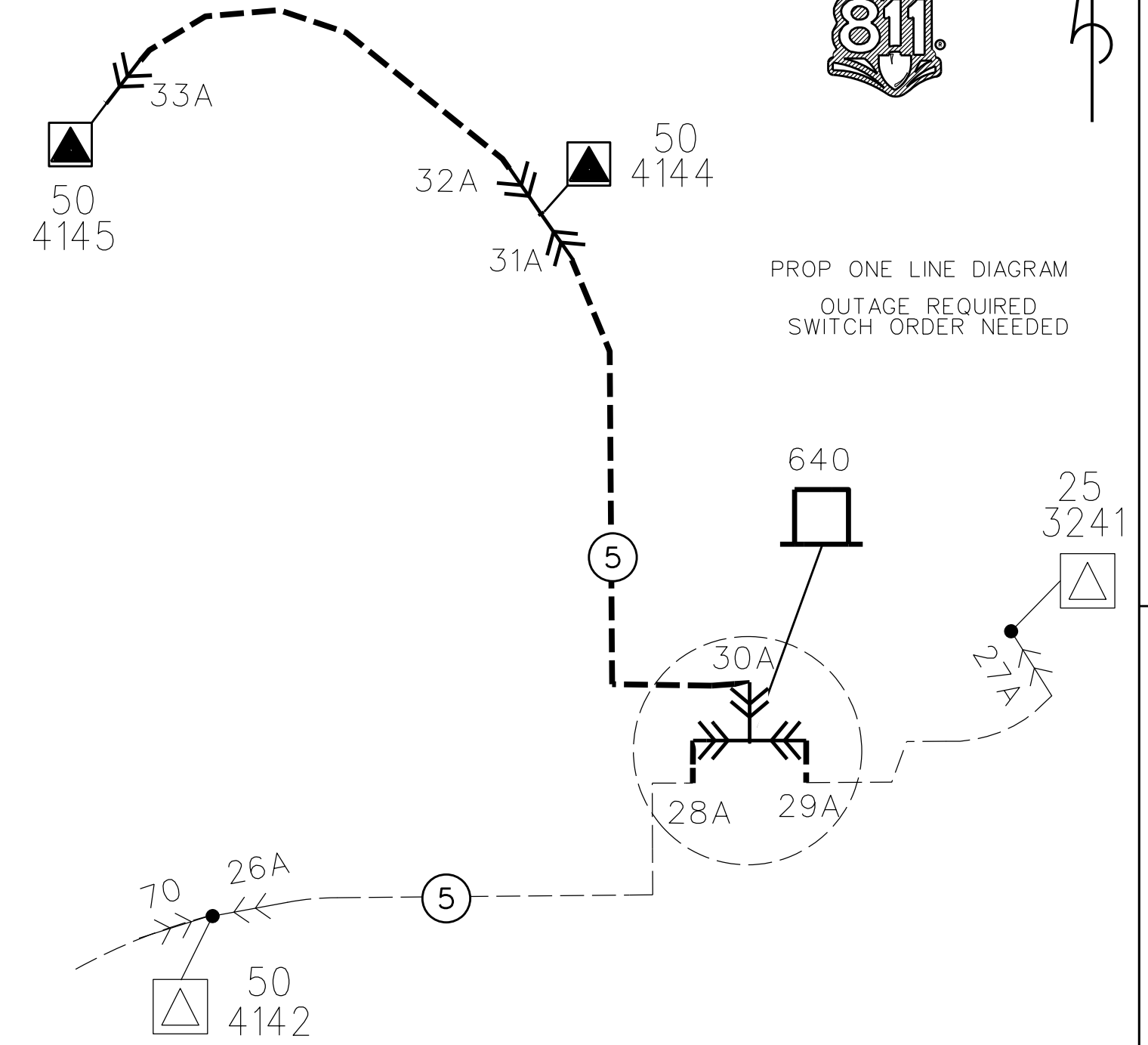

PROP ONE LINE DIAGRAM
OUTAGE REQUIRED
SWITCH ORDER NEEDED

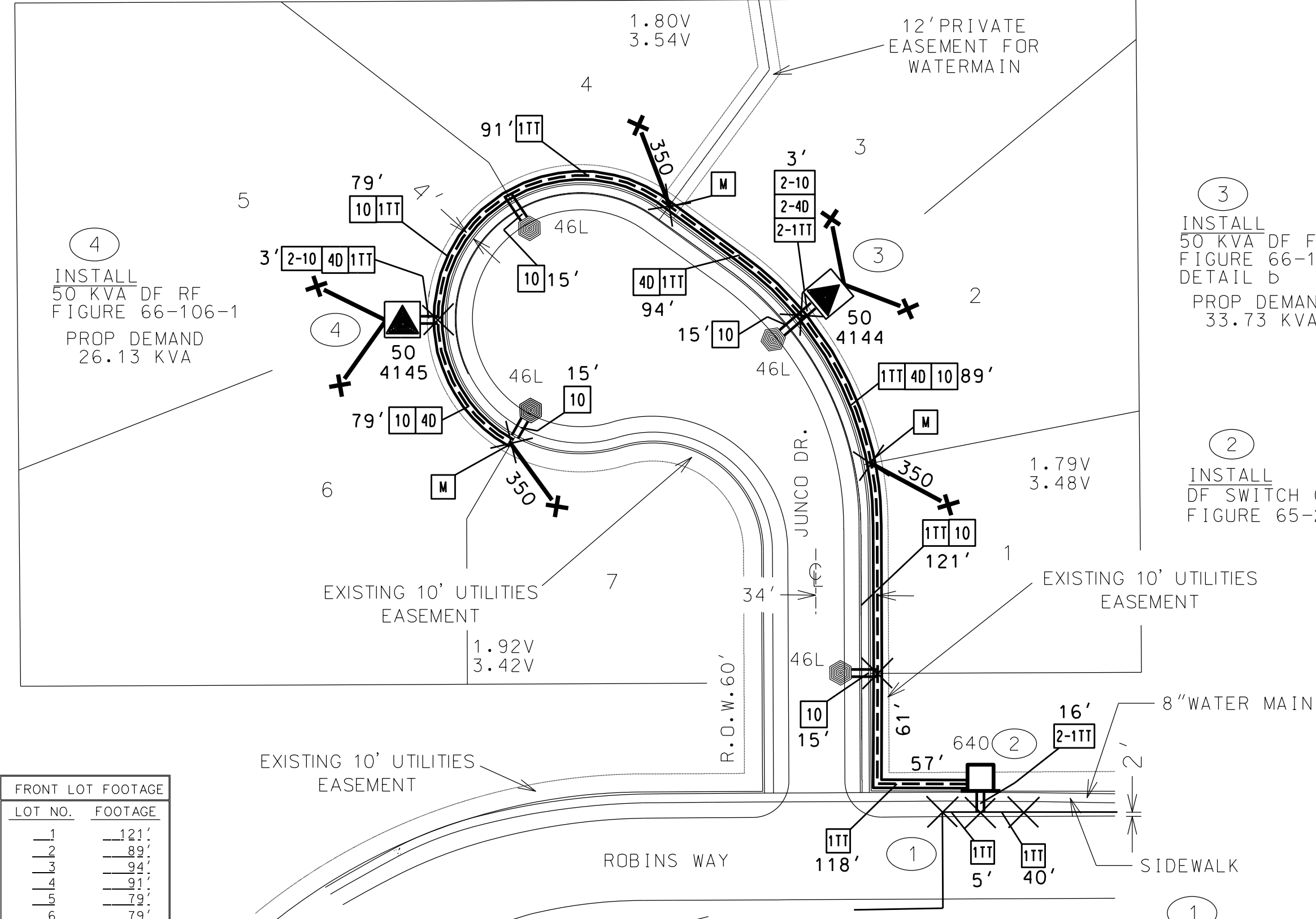

3
INSTALL
50 KVA DF FT
FIGURE 66-106-4
DETAIL b
PROP DEMAND
33.73 KVA

2
INSTALL
DF SWITCH CABINET
FIGURE 65-212-1

1
INSTALL
CABLE, TRENCH
AND SPLICES

Form 931 condensed	CATV		Phone		Non-CE		Other	
	Size	Ft.	Size	Ft.	Gas	Elec.	Size	Ft.
Wire installed is the Trench Footage of the largest Non-CE wire placed.								
Trench (Feet-Joint with CE)								
Trench (Feet-Not Joint with CE)								
Wire Install (Feet-non CE wire placed)								
Pull thru conduit (feet-of conduit)								
Boring (diameter of bore+feet bored)								
Pedestal(s) installed								
Misc Comments:								

LOT NO.	FOOTAGE
1	121'
2	89'
3	94'
4	91'
5	79'
6	79'
7	246'
TOT	799'

NOTE: THERE IS AN 8" WATER MAIN UNDER SIDEWALK EXACT LOCATION NOT KNOWN

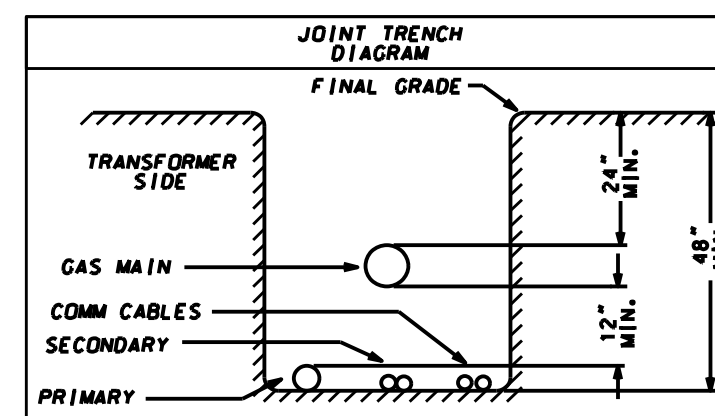

UNDERGROUND LEGEND		DUCT		CABLE MATERIAL AND SIZE	
1. Single-phase primary	[Symbol]	P2	2" Plastic	A.	No 2 AL cable (175 mils INS, or secondary).
2. Open wye primary	[Symbol]	P3	3" Plastic	B.	No 1/0 AL cable (175 mils INS, or secondary).
3. Three-phase primary	[Symbol]	P4	4" Plastic	C.	No 3/0 AL cable (175 mils INS, or secondary).
4. Single-phase secondary	[Symbol]	P6	6" Plastic	D.	350 kcmil AL cable (175 mils INS, or secondary).
5. Combination light and power secondary	[Symbol]	S2	2" Steel	E.	500 kcmil Cu cable (175 mils INS, or secondary).
6. Three-phase power secondary	[Symbol]	S3	3" Steel	F.	750 kcmil AL cable (175 mils INS, or secondary).
7. Single-phase service	[Symbol]	S4	4" Steel	G.	No 1/0 stranded AL cable, 280 mils INS
8. Combination lighting and power service	[Symbol]	S6	6" Steel	H.	No 3/0 stranded AL cable, 280 mils INS
9. Three-phase power service	[Symbol]			I.	750 kcmil AL cable, 280 mils INS
10. Streetlighting conductor (2/C No. 10 CU)	[Symbol]			J.	Cable joint.
11. Streetlighting conductor (2/C No. 8 AL)	[Symbol]			K.	350 kcmil AL cable, 260 mils INS
12. Covered 600V neutral conductor for ducts	[Symbol]			L.	Transformer
TRENCH SYMBOLS				M.	Marker to locate cable
[Symbol]	PROP. ELEC. CONDUCTORS ONLY			N.	Refer to Note on Drawing for Note 1, etc.
[Symbol]	PROP. ELEC. AND GAS LINES ONLY			R.	No 1/0 AL solid cable, 280 mils INS
[Symbol]	PROP. GAS LINE ONLY			T.	No 1/0 AL stranded cable, 280 mils INS, Jacketed
[Symbol]	PROP. ELEC., GAS AND TELEPHONE			TT.	No 1/0 AL stranded cable, 260 mils tree-retardant INS, Jacketed
[Symbol]	EXIST. ELEC. CONDUCTORS ONLY			V.	350 kcmil AL cable, 260 mils INS, Jacketed.
[Symbol]	EXIST. GAS LINE ONLY			VT.	350 kcmil AL cable, 260 mils tree-retardant INS, Jacketed.
[Symbol]	FUTURE ELECTRIC TRENCH			W.	750 kcmil AL cable, 280 mils INS, Jacketed.
[Symbol]	CONDUCTOR CHANGE			WT.	750 kcmil AL cable, 260 mils tree-retardant INS, Jacketed.

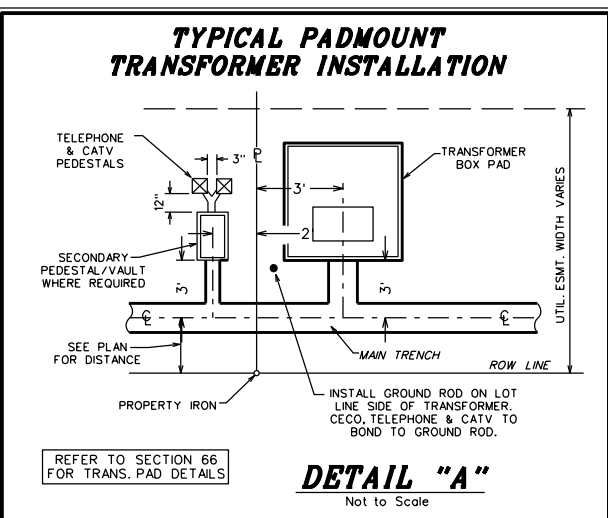

ELECTRIC DESIGN BASIS	
1.	Plan for homes in range 36-45 SF.
2.	For demand assume 23 kva for each homestead.
3.	Plan for 5 Jan A/C for each homestead.

GENERAL UNDERGROUND STREETLIGHT NOTES	
1.	Install 4' 48" LED traditional fixtures on black fiberglass poles.
2.	Poles are to be installed 2'-6" behind curb. Streetlight cable is stubbed in marker posts.

STREETLIGHT PROPOSAL	
1.	14 ft mounting ht fiberglass poles @ \$ 0.00 each = \$ 0.00
2.	1860 LED @ \$ 290.00 each = \$ 540,600.00
3.	Fixed Charge for Streetlighting @ \$ 100.00 each = \$ 500.00
TOTAL = \$ 541,100.00	

APPROX. ANNUAL ENERGY CHARGES	
1.	Annual energy charges: -46W LED @ \$ 95.52 each = \$ 382.08

STREETLIGHT LEGEND	
[Symbol]	EXISTING LIGHT
[Symbol]	PROPOSED LIGHT
[Symbol]	FUTURE LIGHT
S	8500 LUMEN HIGH-PRESSURE SODIUM LUMINAIRE
8.5	8.5 WATT LIGHT EMITTING DIODE LUMINAIRE
L	86 WATT LIGHT EMITTING DIODE LUMINAIRE
86W	86 WATT LIGHT EMITTING DIODE LUMINAIRE

SUBSTATION	WD NO.				
HAGADORN	816				
CIRCUIT	CKT NO.	LCP NO.	TLM NUMBER	# OF RODS	OHMS
HAGADORN	Q3	Q481	04013241		
CE STAKING REQ'D <input checked="" type="checkbox"/> Yes <input type="checkbox"/> No					
FORESTRY REQ'D <input type="checkbox"/> Yes <input checked="" type="checkbox"/> No					

SANCTUARY PHASE 3 OKEMOS			
CM NO. 100006989466			
ORDER TYPE	MAT. TYPE	NOTIFICATION NUMBER	DESIGN NUMBER
ECNC	JLN	1063307168	11431612
ECNC	STL	1063687363	11431613

METER ORDER NUMBER	METER NUMBER	READ	METER LOCATION

JOB PURPOSE:		
CUST REQUESTED UG PRIMARY LINE EXT SERVE RES HOMES		
UPSTREAM SECTIONALIZING DEVICE:		
SW 26A AT TLM 4142		
LOCATION:		
IN FRONT OF ADDRESS 2547 ROBINS WAY		
CONSUMERS ENERGY CONTACTS		
DEPARTMENT	NAME	NUMBER
COORDINATOR	BOB BEAGAN	517.282-2106
DESIGNER	SAW ALAGNA	517.374-2415



To: Board Members

**From: Dan Opsommer, Deputy Township Manager
Director of Public Works & Engineering**

**Younes Ishraidi, Township Engineer
Deputy Director of Public Works & Engineering**

Date: July 1, 2026

**Re: Sierra Ridge #4 Public Streetlighting Improvement Special Assessment
District #431 – Resolution #4**

A request was received from the property owners of Sierra Ridge #4 for maintenance of streetlights within the Sierra Ridge #4 plat. The developer of the Sierra Ridge #4 plat paid Consumers Energy to install four (4) 47-watt LED streetlights with Traditional fixtures with cut-off, and standard fiberglass poles along Fresno Lane. This streetlight special assessment district (SAD) will fund the ongoing maintenance and electrical service cost of the streetlights.

The proposed first year cost for streetlighting in Sierra Ridge #4 is \$1,457.76 (\$104.13/lot) and the cost annually thereafter will be \$728.88 (\$52.06/lot) (subject to annual adjustment).

At its March 3, 2026 meeting, the Township Board held the first of two public hearings to hear objections to the improvement, cost estimate, and assessment district. The Township Board also adopted resolution #3.

This evening we are bringing resolution #4 to the Board to set the second and final public hearing for August 18, 2026.

Proposed Motion:

MOVE TO APPROVE THE SIERRA RIDGE #4 PUBLIC STREETLIGHTING IMPROVEMENT SPECIAL ASSESSMENT DISTRICT #431 – RESOLUTION #4, WHICH FILES THE PROPOSED SPECIAL ASSESSMENT ROLL WITH THE OFFICE OF THE TOWNSHIP CLERK AND SETS THE DATE FOR A PUBLIC HEARING ON TUESDAY, AUGUST 18, 2026.

Attachments:

1. Resolution #4
2. Proposed Assessment Roll
3. Authorization for change in standard lighting contract form 547
4. Prints

**SIERRA RIDGE #4 PUBLIC STREETLIGHTING IMPROVEMENT
SPECIAL ASSESSMENT DISTRICT NO. 431**

RESOLUTION NO. 4

At a regular meeting of the Township Board of the Charter Township of Meridian, Ingham County, held at the Meridian Township Municipal Building, 5151 Marsh Road, Okemos, MI 48864-1198, Phone (517) 853-4000, on Tuesday, July 7, 2026, at 6:00 p.m.

PRESENT: _____

ABSENT: _____

The following resolution was offered by _____
and supported by _____.

WHEREAS, by resolution adopted March 3, 2026, the Township Board of the Charter Township of Meridian, determined to operate and maintain four (4) 47-watt LED streetlights with Traditional fixtures with cut-off, and standard fiberglass poles along Fresno Lane and assess the cost thereof to the property deemed benefited by said improvements, all in accordance with Act 188, Public Acts of Michigan, 1954, as amended; and

WHEREAS, the Supervisor has prepared and reported to the Township Board a special assessment roll assessing the cost of said improvements to the properties benefited thereby with the proper certificate attached thereto.

NOW, THEREFORE, BE IT RESOLVED BY THE TOWNSHIP BOARD OF THE CHARTER TOWNSHIP OF MERIDIAN, INGHAM COUNTY, MICHIGAN, AS FOLLOWS:

1. The plans showing the improvement and location thereof and an estimate of the cost thereof be filed with the Township Clerk and be available for public examination during regular working hours on regular working days.
2. Said special assessment roll shall be filed with the Office of the Township Clerk and shall be available for public examination during regular working hours on regular working days.
3. The Township Board shall meet at 6:00 p.m. on Tuesday, August 18, 2026, at the Meridian Township Municipal Building, 5151 Marsh Road, Okemos, Michigan, in the Charter Township of Meridian, for the purpose of reviewing and hearing objections to the special assessment roll.
4. The Township Clerk shall cause notice of such hearing and the filing of the assessment roll to be published twice in a newspaper of general circulation in the Township, prior to the date of the hearing. The first publication shall be at least ten (10) days before the hearing pursuant to Act 162, Public Acts of 1962. The Clerk shall also cause notice of such hearing to be mailed by first class mail to all property owners in the special assessment district shown on the current assessment rolls of the Township, at least ten (10) full days before the date of said hearing. Said notice as published and mailed shall be in substantially the following

form: (SEE ATTACHED)

5. All resolutions and parts of resolutions insofar as they conflict with the provisions of this resolution be and the same are hereby rescinded.

ADOPTED:

YEAS: _____

NAYS: _____

Resolution declared adopted.

STATE OF MICHIGAN)

) ss.

COUNTY OF INGHAM)

I, the undersigned, the duly qualified and acting Clerk of the Charter Township of Meridian, Ingham County, **DO HEREBY CERTIFY** that the foregoing is a true and complete copy of proceedings taken by the Township Board at a regular meeting held on Tuesday, July 7, 2026.

Angela Demas, Township Clerk

**SIERRA RIDGE #4 PUBLIC STREETLIGHTING IMPROVEMENT
SPECIAL ASSESSMENT DISTRICT NO. 431**

NOTICE OF HEARING

**TO THE RECORD OWNERS OF, OR PARTIES IN INTEREST IN, THE FOLLOWING PROPERTY
CONSTITUTING THE PROPOSED SPECIAL ASSESSMENT DISTRICT:**

Lots 70 through 83 (inclusive), Sierra Ridge #4

PLEASE TAKE NOTICE that a special assessment roll for the Sierra Ridge #4 Public Streetlighting Improvement Special Assessment District #431 has been prepared and is on file in the Office of the Township Clerk for public examination.

Said special assessment roll has been prepared for the purpose of assessing the cost of the above described public improvements to the property benefited therefrom. All questions and/or concerns should be directed to Meridian Township Department of Public Works & Engineering at (517) 853-4440.

TAKE FURTHER NOTICE that the Township Board will meet on **Tuesday, August 18, 2026, at 6:00 p.m.** at the Meridian Township Municipal Building, 5151 Marsh Road, Okemos, MI 48864-1198, for the purpose of reviewing said special assessment roll and hearing objections thereto.

An owner or party in interest, or his or her agent, may appear in person at the hearing to protest the special assessment, or shall be permitted to file his or her appearance or protest by letter with the Township Clerk before the close of this hearing, and his or her personal appearance is not required. The owner or any person having an interest in the real property who protests in person or in writing at the hearing may file a written appeal of the special assessment with the Michigan Tax Tribunal within 30 days after the confirmation of the special assessment roll.

**"FOR PURPOSES OF THIS HEARING, THE AMOUNT TO BE ASSESSED AGAINST YOUR PROPERTY
IS ESTIMATED TO BE: First Year Cost: \$104.13/Lot
 Annual Thereafter: \$52.06/Lot**

Dated: _____

Angela Demas, Township Clerk
CHARTER TOWNSHIP OF MERIDIAN

**SIERRA RIDGE #4 PUBLIC STREETLIGHTIN IMPROVEMENT
SPECIAL ASSESSMENT DISTRICT NO. 431**

ASSESSMENT ROLL

Lot 70 through 83 (inclusive), Sierra Ridge #4.

Legal Description/ Address	Property Owner & Address	First Year Cost	Annually Thereafter
33-02-02-04-401-008 (Lot 70) 6109 Fresno Lane	G S Fedewa Builders Inc 6099 E Lake Drive Haslett, MI 48840	\$104.13	\$52.06
33-02-02-04-401-009 (Lot 71) 6111 Fresno Lane	G S Fedewa Builders Inc 6099 E Lake Drive Haslett, MI 48840	\$104.13	\$52.06
33-02-02-04-401-010 (Lot 72) 6113 Fresno Lane	G S Fedewa Builders Inc 6099 E Lake Drive Haslett, MI 48840	\$104.13	\$52.06
33-02-02-04-401-011 (Lot 73) 6115 Fresno Lane	G S Fedewa Builders Inc 6099 E Lake Drive Haslett, MI 48840	\$104.13	\$52.06
33-02-02-04-401-012 (Lot 74) 6117 Fresno Lane	G S Fedewa Builders Inc 6099 E Lake Drive Haslett, MI 48840	\$104.13	\$52.06
33-02-02-04-401-013 (Lot 75) 6119 Fresno Lane	G S Fedewa Builders Inc 6099 E Lake Drive Haslett, MI 48840	\$104.13	\$52.06
33-02-02-04-401-014 (Lot 76) 6121 Fresno Lane	G S Fedewa Builders Inc 6099 E Lake Drive Haslett, MI 48840	\$104.13	\$52.06
33-02-02-04-401-015 (Lot 77) 6123 Fresno Lane	Hulbanni, Mallikarjuna and Shilpa 6123 Fresno Lane East Lansing, MI 48823	\$104.13	\$52.06
33-02-02-04-401-016 (Lot 78) 6125 Fresno Lane	Hulbanni, Sharada 6125 Fresno Lane East Lansing, MI 48823	\$104.13	\$52.06
33-02-02-04-403-001 (Lot 79) 6120 Fresno Lane	G S Fedewa Builders Inc 6099 E Lake Drive Haslett, MI 48840	\$104.13	\$52.06

33-02-02-04-403-002 (Lot 80) 6118 Fresno Lane	Presutti, John and Patricia 6118 Fresno Lane East Lansing, MI 48823	\$104.13	\$52.06
33-02-02-04-403-003 (Lot 81) 6116 Fresno Lane	Redwine, Carmen and Cleavon 6116 Fresno Lane East Lansing, MI 48823	\$104.13	\$52.06
33-02-02-04-403-004 (Lot 82) 6114 Fresno Lane	G S Fedewa Builders Inc 6099 E Lake Drive Haslett, MI 48840	\$104.13	\$52.06
33-02-02-04-403-005 (Lot 83) 6112 Fresno Lane	G S Fedewa Builders Inc 6099 E Lake Drive Haslett, MI 48840	\$104.13	\$52.06

(Subject to annual increases)



AUTHORIZATION FOR CHANGE IN STANDARD LIGHTING CONTRACT (COMPANY-OWNED) FORM 547

Contract Number: 103025042856

Consumers Energy Company is authorized as of _____, by the Township of MERIDIAN, to make changes, as listed below, in the lighting system(s) covered by the existing Standard Lighting Contract between the Company and the Township of MERIDIAN, dated 1/6/2016.

Lighting Type:

General Unmetered Light Emitting Diode Lighting Rate GU-LED

Notification Number(s):

1056704175

Construction Work Order Number(s):

Except for the changes in the lighting system(s) as herein authorized, all provisions of the aforesaid Standard Lighting Contract dated 1/6/2016 shall remain in full force and effect.

Township of MERIDIAN

By:

(Signature)

(Printed)

Its

(Title)

This Agreement may be executed and delivered in counterparts, including by a facsimile or an electronic transmission thereof, each of which shall be deemed an original. Any document generated by the parties with respect to this Agreement, including this Agreement, may be imaged and stored electronically and introduced as evidence in any proceeding as if original business records. Neither party will object to the admissibility of such images as evidence in any proceeding on account of having been stored electronically.

RESOLUTION

RESOLVED, that it is hereby deemed advisable to authorize Consumers Energy Company to make changes in the lighting service as provided in the Standard Lighting Contract between the Company and the Township of MERIDIAN, dated 1/6/2016, in accordance with the Authorization for Change in Standard Lighting Contract dated _____, heretofore submitted to and considered by this commission council board ;and

RESOLVED, further, that the _____ Clerk be and are authorized to execute such authorization for change on the behalf of the Township .

STATE OF MICHIGAN

COUNTY OF Ingham

I, _____, Clerk of the Township of MERIDIAN, do hereby certify that the foregoing resolution was duly adopted by the commission council board of said municipality, at the meeting held on _____.

Dated:

Municipal Customer Type: Township

GENERAL UNMETERED LIGHT EMITTING DIODE LIGHTING RATE GU-LED

<i>Number of Luminaires</i>	<i>Nominal Watts</i>	<i>Luminaire Type</i>	<i>Fixture Type</i>	<i>Fixture Style</i>	<i>Install Remove</i>	<i>Location</i>
1	47	LED	Post Top	Traditional C	Install	FRENZO LN - BETWEEN LOT 89 &
1	47	LED	Post Top	Traditional C	Install	FRENZO LN - BETWEEN LOT 91 &
1	47	LED	Post Top	Traditional C	Install	FRENZO LN - BETWEEN LOT 91 &
1	47	LED	Post Top	Traditional C	Install	FRENZO LN - BETWEEN LOT 95 &

SCOPE OF WORK:

CUSTOMER REQUESTED JOINT UNDERGROUND LINES FOR NEXT PHASE OF SUBDIVISION DEVELOPMENT.

PER LVDP, NEED TO EXTEND 3 PHASE PRIMARY DOWN NEWTON RD AND RUN INTO EXISTING DEAD FRONT SWITCH.

MULTIPLE NOTIFICATIONS/ORDERS:

- ESIC OHL: OVERHEAD WORK ALONG NEWTON RD
- ESIC UGL: RISER AND UG ROAD CROSSING
- ECNC JLN: SUBDIVISION LINES AND XFMR'S
- ECNC STL: SUBDIVISION STREETLIGHTS

OUTAGES REQUIRED ALONG NEWTON RD

1 REMOVE PTP, S8S, (2)SP5

INSTALL S10S, (6)PRI DE (3)SA, (3)CO, (3)100A FUSE FIGURE 25-314-1 (5)SP8 LCP LABEL 578-100

2 REMOVE PRT VDE, FG INS

INSTALL 3PH SLACK SPAN FIGURE 23-153-1 (5)SP8 STRINGING SAG 3'7"

NOTE: REPLACE EXISTING 4+NB FOR SLACK SPAN

3 REMOVE (2)PRI DE, NEUT WR (2)JCOM, (2)LA, (2)CO 10KVA XFMR

INSTALL DBS, (3)SP5, NEUT DE FIGURE 23-153-1 D=5' (EXISTING) (3)PRI DE, NEUT DE FIGURE 23-150-1 XFMR ASSY FIGURE 26-101-1 DETAIL C FGCOM, CO 10KVA XFMR, LA CHECK GRND INST ON SOUTH SIDE OF POLE 11K-FG-P 11K-P }-20'-RT FIGURE 22-101-15

4 INSTALL S8S, (2)SP5 FIGURE 23-140-1 DETAIL A D=5' (EXISTING)

5 INSTALL S8S, (2)SP5 FIGURE 23-140-1 DETAIL A D=11' (EXISTING) REPLACE LCOM/FGCOM, CO LA (POLE MOUNT) FIGURE 26-101-1 DETAIL C TAP TO Y PHASE CHECK GRND

6 REMOVE S8S, SP5

INSTALL PTP, S8S, (2)SP5 FIGURE 23-140-1 DETAIL A D=11' (EXISTING)

7 REMOVE S8S, SP5 (2)WR 11K-P-RS

INSTALL PTP, S8S, (2)SP5 FIGURE 23-140-1 DETAIL A (2)NEUT DE D=18' (EXISTING) XFMR ASSY FIGURE 26-101-1 DETAIL C FGCOM, CO 25KVA XFMR, LA MOUNT AT 30' COMP GRND FGSB FIGURE 23-241-1

8 REMOVE DBS, PRI DE XFMR ASSY (3)SEC WR 11K-P 11K-P}-17'-RT

INSTALL PTP, S8S, (2)SP5, NEUT WR FIGURE 23-140-1 DETAIL A D=18' (EXISTING) XFMR ASSY FIGURE 26-101-1 DETAIL C FGCOM, CO 25KVA XFMR, LA MOUNT AT 30' CHECK GRND FGSB FIGURE 23-241-1

NOTE: SPLICE PRIMARY TRANSFER OH SERVICE

SOURCE: LCP 310 - LBG LAKE LANSING RD S2E PARK LAKE RD

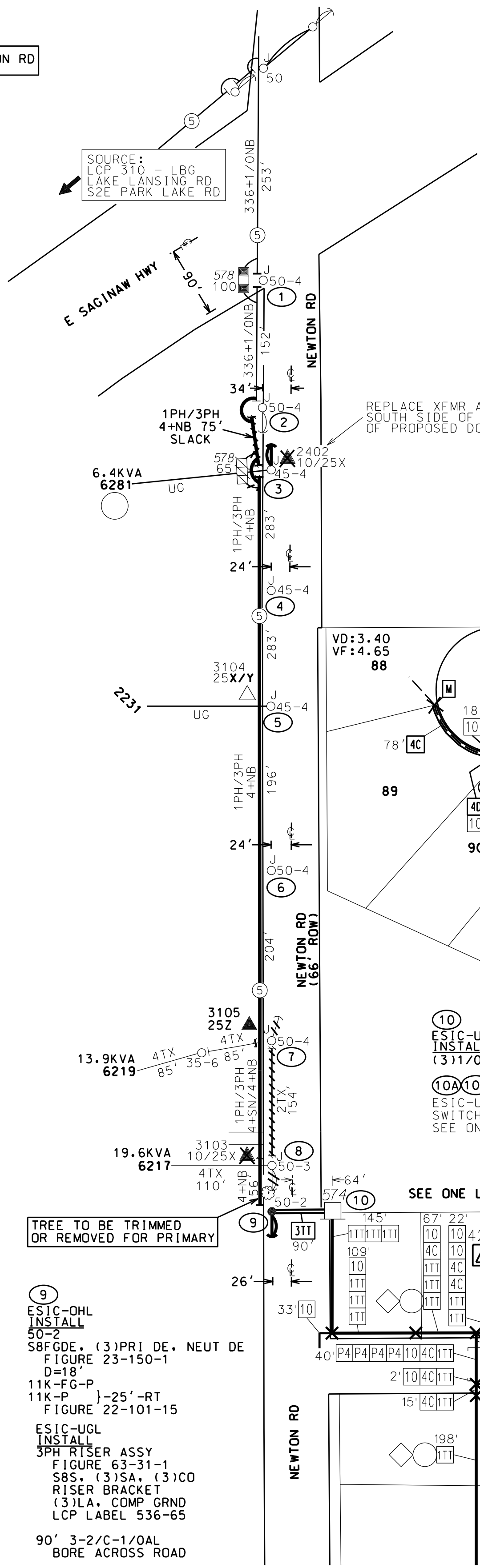

GENERAL NOTES ELECTRIC

- Main trench is to be installed 4 ft behind property lines. (Unless otherwise shown on plan)
- Services are to be stubbed at lot lines and in marker posts except at transformers and pedestals.
- Install cable markers at all other cable stubs.
- Install transformers per Detail "A" and P. 66-106-1 & P. 66-106-2 (EDM).
- Utility easements have been or shall be provided for utility placement.
- Install secondary vaults/pedestals per Detail "A" and P 62-10 (EDM).

Form 931 condensed

Wire installed is the Trench Footage of the largest Non-CE wire placed.

Trench (Feet-Joint with CE)	CATV		Phone		Gas		Elec.		Other	
	Size	Ft.	Size	Ft.	Size	Ft.	Size	Ft.	Size	Ft.
Trench (Feet-Not Joint with CE)										
Wire Install (Feet-Non CE wire placed)										
Pull thru conduit (feet-of conduit)										
Boring (diameter of bore-feet bored)										
Pedestal (s) installed										
Misc Comments:										

MISS DIG System, Inc.
1-800-482-7171

UNDERGROUND LEGEND

1. Single phase primary	A. No 2 AL cable, 175 mils, 15KV, or secondary.
2. Open eye primary	B. No 1/0 AL cable, 175 mils, 15KV, or secondary.
3. Three phase primary	C. No 3/0 AL cable, 175 mils, 15KV, or secondary.
4. Single phase secondary	D. 350 kcmil AL cable, 175 mils, 15KV, or secondary.
5. Combination light and power secondary	E. 500 kcmil copper cable, 175 mils, 15KV, or secondary.
6. Three phase power secondary	F. 750 kcmil AL cable, 175 mils, 15KV, or secondary.
7. Single phase service	G. No 1/0 stranded AL cable, 280 mils, 28KV.
8. Combination lighting and power service	H. No 3/0 stranded AL cable, 280 mils, 28KV.
9. Three phase power service	I. 750 kcmil AL cable, 280 mils, 28KV.
10. Streetlighting conductor (2/C-10 CU)	J. Cable joint.
11. Covered neutral conductor for ducts	K. 350 kcmil AL cable, 260 mils, 25KV.
12. Streetlighting conductor (3/C-1/0 AL)	L. Marker to locate cable
13. Streetlighting conductor (3/C-1/0 AL)	M. Refer to Note on Drawing, NI for Note 1, etc.

CONDUIT

2" Plastic [P2] 3" Plastic [P3] 4" Plastic [P4] 6" Plastic [P6] 8" Plastic [P8]

2" Steel [S2] 3" Steel [S3] 4" Steel [S4] 5" Steel [S5] 6" Steel [S6]

PROF. ELEC. CONDUCTORS ONLY
PROF. ELEC. AND GAS LINES ONLY
PROF. GAS LINE ONLY
EXIST. ELEC. CONDUCTORS ONLY
EXIST. GAS LINE ONLY
FUTURE ELECTRIC TRENCH

CONDUCTOR CHANGE

DEVELOPER TO INSTALL CONDUITS FOR ROAD CROSSINGS

16 17 18 19
INSTALL 14' FG BLACK STLT POLE FIGURE 42-211-1 47W LED TRADITIONAL CUTOFF POST TOP FIXTURE FIGURE 42-215-2

13A INSTALL SEC PEDESTAL FIGURE 64-40-1

13 INSTALL 50 KVA DF RF XFMR ASSY FIGURE 66-106-1

12 INSTALL 50 KVA DF FT XFMR ASSY FIGURE 66-106-5

11 INSTALL 25 KVA DF FTR XFMR ASSY FIGURE 66-106-4

82	116'
83	111'
84	100'
85	100'
86	100'
87	222'
88	147'
89	78'
90	141'
91	100'
92	100'
93	112'
94	119'
95	90'
96	90'

ELECTRIC DESIGN BASIS

- Plan for homes in range 2300-3500 SF.
- For demand assume 10 kva for each homestead.
- Plan for 3 ton A/C for each homestead.

6219 NEWTON RD				
	VOLTAGE DROP	FLICKER	TRANSFORMER DEMAND LOAD (KVA)	MOTOR LOAD
TLM3103 EXISTING	14.94	12.87	27.27	2 TON
TLM3105 PROPOSED	5.12	6.27	13.90	2 TON

6217 NEWTON RD				
	VOLTAGE DROP	FLICKER	TRANSFORMER DEMAND LOAD (KVA)	MOTOR LOAD
TLM3103 EXISTING	12.41	8.65	27.27	2 TON
PROPOSED	5.37	4.65	19.60	2 TON

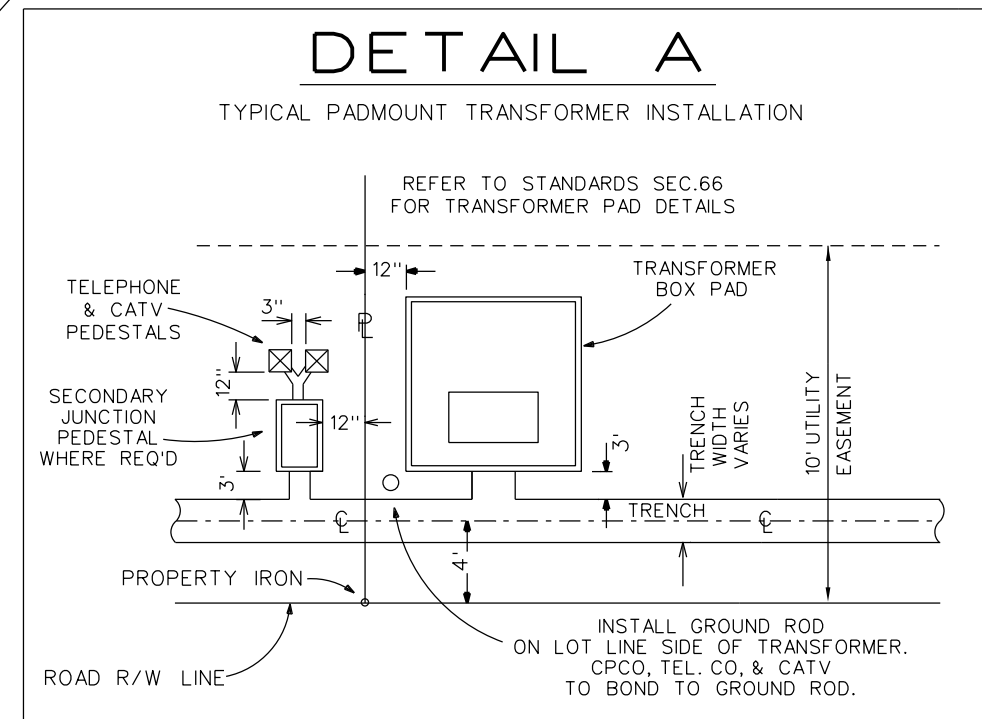

TRANSFORMER LOADS

XFMR	4244	4245	4246
LOTS	94 95 96	82 83 84 85 86 87	88 89 90 91 92 93
LOAD (KVA)	23.34	43.14	43.14

SUBSTATION LAKE LANSING	WD NO. 0194	METER ORDER NUMBER	METER NUMBER	READ	METER LOCATION
CIRCUIT BURCHAM	CKT NO. 03	TLM NUMBER 04010442	DESIGN NUMBER 11362250	ORDER NUMBER	
SIERRA RIDGE PHASE 4 ELAN, ECNC JLN		CM NO. 100006229338	JOB PURPOSE: CUSTOMER REQUESTED JOINT UNDERGROUND LINES FOR NEXT PHASE OF SUBDIVISION DEVELOPMENT.		
ORDER TYPE ECNC	JLN	ALUMBER NUMBER 1056359685	DESIGN NUMBER 11362250	UPSTREAM SECTIONALIZING DEVICE: LCP 310-LBG	
ORDER TYPE ECNC	STL	ALUMBER NUMBER 1056704175	DESIGN NUMBER 11362750	LOCATION: LAKE LANSING RD S2E PARR LAKE RD	
ORDER TYPE ESIC	OHL	ALUMBER NUMBER 1056843204	DESIGN NUMBER 11362258	CONSUMERS ENERGY CONTACTS	
ORDER TYPE ESIC	UGL	ALUMBER NUMBER 1056838827	DESIGN NUMBER 11362256	DEPARTMENT DESIGNER	NAME TYLER STOKES
CE STAKING REO'D <input checked="" type="checkbox"/> Yes <input type="checkbox"/> No	FORESTRY REO'D <input checked="" type="checkbox"/> Yes <input type="checkbox"/> No	INGHAM		CO	MERIDIAN
SHEET D SHEET 1 OF 2		SCALE NTS		TWP T 04N R 01W SEC. 04	



To: Township Board

From: Tim Dempsey, Township Manager
Dan Opsommer, Deputy Township Manager
Director Public Works & Engineering

Date: July 2, 2026

Re: Park and Public Safety Millage Renewals

At the March 3, 2026, Township Board meeting, staff reviewed the status of Township millages. The Park Millage expired in 2025 and the 2017 Police and Fire Millage expires this year. Both millages are essential for providing critical services that Township residents rely upon daily.

Park Millage

The Park Millage (0.6522) generates just over \$1.5 million annually to enhance, operate, and maintain Township parks. This millage has been in place since 1984 and is only exceeded in duration by the Township’s General Operating Millage (1959) and Pathways Millage (1974). These funds are essential to maintaining the 30 parks throughout the Township’s system—providing critical support to staffing and operations. For Fiscal Year 2026 (2025 millage), the Park Millage Fund expenses are allocated as follows:

Activity	Amount
Administration	\$261,631
Harris Nature Center	\$259,827
Park Maintenance	\$590,849
Capital Improvements	\$809,600
Total	\$1,921,907*

** Fund is also supported by grant revenue and user/rental fees*

The Township did let a 0.3160 mill Park Millage levy expire in 2016 to help offset the increase of the 2017 Police and Fire Millage by just over 21%.

Police and Fire Millage

The 2017 Police and Fire Millage (1.4606) generates just over \$3.4 million annually to address long-term pension liabilities, provides four additional staff members for the Police (2) and Fire (2) Departments, and supports ongoing public safety equipment needs. Additional Police and Fire pension contributions have been \$1.5 million per year, with an additional \$684,000 in 2021-2022. In 2017, when this was originally adopted, the Township’s overall pension was funded at 56%, today it stands at 76%. While the funding ratio has improved, the Township does continue to accrue pension obligations that require ongoing investment.



Specifically, this millage was critical in being able to replace our two fire engines in 2024 and 2025, our ladder truck in 2022, and three ambulances in 2019, 2022, and 2026. This millage has also helped replace additional equipment and vehicles used by our first responders to serve the community.

If this millage is not renewed, we would likely see our Insurance Services Office (ISO) fire rating score decrease. An ISO fire rating is a score provided to fire departments and insurance companies by ISO. The score reflects how prepared a community is to suppress fires. If our ISO fire rating score decreases, [the cost of homeowners' insurance in the Township would likely increase.](#)

Combined, these two millages will generate approximately \$4.9 million in revenue for the current fiscal year. For context, the 2017 Police and Fire Millage represents just over 15% of all general fund revenue. The public safety millage is just over 18% of the combined \$18.5 million Police and Fire budgets. Losing one or both millages would have significant, negative impacts on the Township's operations and fiscal stability. It would require eliminating positions, we would no longer be able to replace some of our Police and Fire equipment and vehicles (including fire engines), and would significantly impact operations.

As shared during the March 3 meeting, it was my strong recommendation that the Township Board consider placing these millages before voters for renewal. During that meeting, it was the consensus of the Board to bring these back for consideration during the summer and in time for placement on the November ballot. The deadline for submitting election ballot wording for the November General Election is Tuesday, August 11, 2026, at 4 pm.

The table below shows approximately how much a property owner currently pays annually for these two millages. Many property owners who have lived in their home for an extended period would pay less than the figures shown below as their taxable value is less than half of their market value due to the cap imposed by Proposal A of 1994:

Highest Possible Property Taxes Based on Market Value of Home				
Market Value	Taxable Value	Park Millage	Police & Fire Millage	Total
\$200,000	\$100,000	\$65	\$146	\$211
\$250,000	\$125,000	\$82	\$183	\$264
\$300,000	\$150,000	\$98	\$219	\$317
\$350,000	\$175,000	\$114	\$256	\$370
\$400,000	\$200,000	\$130	\$292	\$423
\$500,000	\$250,000	\$163	\$365	\$528



11.A

Staff will provide a presentation on the use of these millages at Tuesday's meeting. Should the Board wish to proceed with placing these millage renewals on the November ballot, staff will prepare the final authorizing resolutions for consideration at the July 21, 2026 meeting. The draft resolutions are attached.



Meridian Township Millage Renewals

July 7, 2026



Current Township Millages & Revenue

Millage (Original Enactment)	Last Approval	Expiration Data	Rate When Last Enacted	2026 ⁽¹⁾	2027	2028	2029	2030	2031	2032	FY 2026 Estimated Revenue
Township Operating (1959)	Dec-1959	N/A	5.0000	4.0996	4.0996	4.0996	4.0996	4.0996	4.0996	4.0996	\$9,604,000
Police Protection (1998)	Nov-2020	Dec-2035	0.6016	0.5930	0.5930	0.5930	0.5930	0.5930	0.5930	0.5930	\$1,389,000
Fire Protection (1998)	Nov-2020	Dec-2035	0.6339	0.6248	0.6248	0.6248	0.6248	0.6248	0.6248	0.6248	\$1,464,000
Community Services (2002)	Aug-2022	Dec-2031	0.1483	0.1460	0.1460	0.1460	0.1460	0.1460	0.1460		\$342,000
Land Preservation (2000)	Nov-2020	Dec-2029	0.1000	0.0984	0.0984	0.0984	0.0984				\$231,000
Pathways (1974)	Aug-2016	Dec-2028	0.3333	0.3260	0.326	0.326					\$764,000
Local Roads Debt (2019)	Aug-2019	Dec-2027 ⁽²⁾	1.9429	1.9429	1.0625						\$4,494,000
Police and Fire (2017)	Aug-2017	Dec-2026	1.4830	1.4563							\$3,412,000
Park (1984)	Aug-2014	Dec-2025	0.6667	0.6503 ⁽³⁾							\$1,524,000
Total Twp. Millage Rate			11.1097	9.2870	6.9503	5.8878	5.5618	5.4634	5.4634	5.3174	\$23,224,000
Total TWP. Millage Rate Less Debt			8.9668	7.3441	5.8878	5.8878	5.5618	5.4634	5.4634	5.3174	

(1) Tentative rates; 2027 and beyond are pending Headlee rollback calculations

(2) Current estimate of final year

(3) Expired 2025, rate if approved by voters



Millage Highlights

- Parks Millage expired in 2025 (0.6522 mill)
 - Generates \$1.5 million annually
 - Used to fund park improvements, operations, and maintenance
- Public Safety Millage expires in 2026 (1.4563 mills)
 - Generates \$3.4 million annually
 - Used to fund police and fire staff and needed equipment
 - Significant additional pension contributions to reduce the Township's long-term pension liability. The Township's funded status for the pension system has increased from 56% to 80% since 2017 as a result.
- Both millages also support the Motor Pool for respective departments



Police Department

- Where were we in 2017?
 - 38 Sworn Officers
 - 17,926 Calls for Service
 - 2,188 Citations Issued





Police Department

- Where are we today?
 - 41 Sworn Officers
 - 21,173 Calls for Service
 - 3,559 Citations





Police Department

- Current Staffing
 - 2 School Resource Officers
 - 2 Officers assigned to traffic safety
 - 4 Officers and one Sergeant assigned to every shift





Police Department

- Why is this important?
 - Patrol vehicles are cycled out after 3 years (approximately 90,000 miles)
 - High standards for hiring and retaining employees
 - Proactive policing and community policing
 - Better response times
 - State mandated training requirements





Fire Department

- Calls for service increase since 2017
 - 2017: 5169
 - 2025: 6805
 - 32% increase in 8 years
- Supported multiple large equipment purchases since 2019 to meet OSHA and NFPA standards:
 - Two fire engines and a ladder truck
 - Three ambulances





Fire Department



- Staffing adjustments:
 - 2017: 30 firefighters/EMS
 - 2025: 36 firefighters/EMS
 - Two additional firefighters hired in 2018 with millage resources
 - Supports hiring quality firefighters
- Support national best practices (NFPA 1710) for staffing levels and response times:
 - Four minutes for initial arriving fire engine at fire
 - Eight minutes for full complement of 16 firefighters minimum at structure fire



Fire Department

- Insurance Services Office (ISO) rating that assigns a public protection classification to jurisdictions base on fire department services.
- Meridian Twp. is a Class 3 ratings (1 being the best, 10 the lowest)
- A higher community protection factor helps reduce insurance rates
- Evaluation factors:
 - Staffing
 - Response times
 - Annual training
 - Equipment, including ladder trucks and engines
 - Water supply, including public system



Parks Department

- Thirty parks, recreational facilities, and extensive programming requires significant staffing, 13 full-time and multiple part-time staff, including:
 - Director and Administrative Assistant
 - Parks and Land Stewardship Superintendent
 - 6 Full-time Utility Workers (maintenance) and
 - 5 Part-time Seasonal Maintenance Workers
 - 2 Recreation Specialists
 - Market Manager and Assistant Manager
 - Stewardship Coordinator and 4 Part-time Stewardship Assistants
 - 1 Senior Naturalists
 - 7 Part-time Assistant Naturalists
 - 1 Recreation and Policy intern



Harris Nature Center Crew



Park Maintenance Crew



Stewardship Crew



Parks Department

• Park Improvements from 2022-2026

- Installed 5 floating islands and wetland buffer in Central Park South
- Upgraded bathrooms with heat at Marketplace on the Green
- Building maintenance survey and repairs to the Historical Village
 - New roofs on farmhouse, Barne's house, and barn; upgraded electrical system at the Barne's house; upgraded to LED lights throughout; new paint on schoolhouse and chapel
- Installed shade structure at Towner Rd Park pickleball courts
- Added a permanent POD to farmers market for food assistance programs and installed windscreens at the Marketplace
- Central Park pavilion remodel with new siding, roof, barn doors, ceiling, lights, bathrooms, Farmers' Market murals, and additional handicap parking
- Upgrades to Harris Nature Center including split rail fence, railings on overlook deck, indoor classroom, new features in the nature exploration area.
- New play structures at Marshall Park, Ottawa Hills Park and Towner Rd. Park
- Added wind screens at the pickleball courts





Parks Department

Park Improvements from 2022-2026

- New play structures at Marshall Park, Ottawa Hills Park and Towner Road Park
- Native species plantings in Indian Hills, Forest Hills, Marshall Park and Central Park South
- State Designation of the Red Cedar Watertrail
- Accessible floating dock at Harris Nature Center





Parks Department

Maintenance Activities

- Resurfaced parking lots at Ferguson Park, Ted Black Woods, North Meridian Road, and Harris Nature Center
- Built a sled library and snowshoe racks, ice skating closet, upgraded baseball fields and backstops, installed AEDs and provided preventative maintenance on pickleball courts
- Replenished volleyball courts with Michigan beach sand
- Upgraded parking lot lights at Harris Nature Center to make them Dark Sky friendly
- Mow 215 acres per year; purchased three robot mowers to maintain lawn
- Snowplow 90 miles of pathway per year
- Installed new picnic tables throughout parks
- Upgrades to playground equipment at Ferguson, Hillbrook, Orlando, Cedar Bend Heights, North Meridian Rd, Nancy Moore, Hartrick, Wonch, and Towar Parks
- And MUCH more

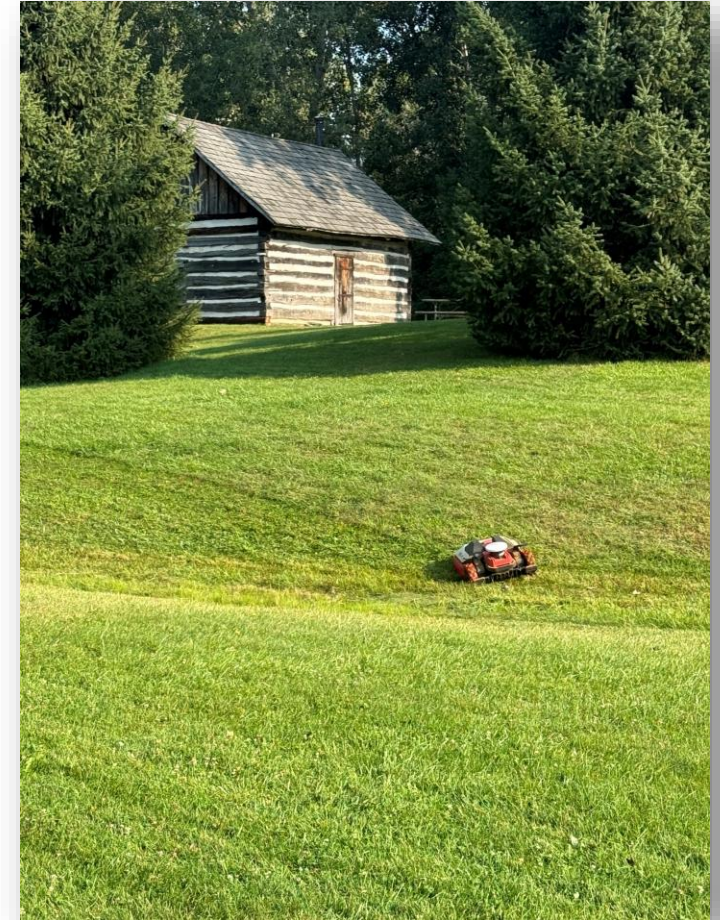



Parks Department

Proposed Future Improvements

- Develop the Central Meridian Trailhead at Nancy Moore Park
- Nancy Moore Park play structure replacement and installation of loop trail
- Preventative maintenance on pickleball courts
- Upgrade Nancy Moore Park pavilion and restrooms
- Install shelter at the Small Dog Park
- Clean and seal roof and paint the Tollgate House at the Village
- Continued maintenance of the Red Cedar Watertrail
- Marketplace electrical upgrades
- Parking lot expansions at Hartrick, North Meridian, and Harris Nature Center Parks





Ongoing Needs - Pension Funding

Year	Total Obligation	Assets	Unfunded	% Funded
2024	\$98,061,937	\$73,547,981	\$24,513,956	75%
2023	\$93,588,566	\$69,492,356	\$24,096,210	74%
2022	\$87,580,156	\$64,528,517	\$23,051,639	74%
2021	\$84,252,364	\$60,838,360	\$23,414,004	72%
2020	\$79,103,874	\$50,849,504	\$28,254,370	64%
2019	\$74,014,966	\$46,002,599	\$28,012,367	62%
2018	\$68,549,666	\$43,010,072	\$25,539,594	63%
2017	\$65,850,156	\$40,461,002	\$25,389,154	61%
2016	\$64,160,503	\$37,221,865	\$26,938,638	58%
2015	\$61,743,003	\$34,930,549	\$26,812,454	57%



Ongoing Needs - Motor Pool

Fund Balance

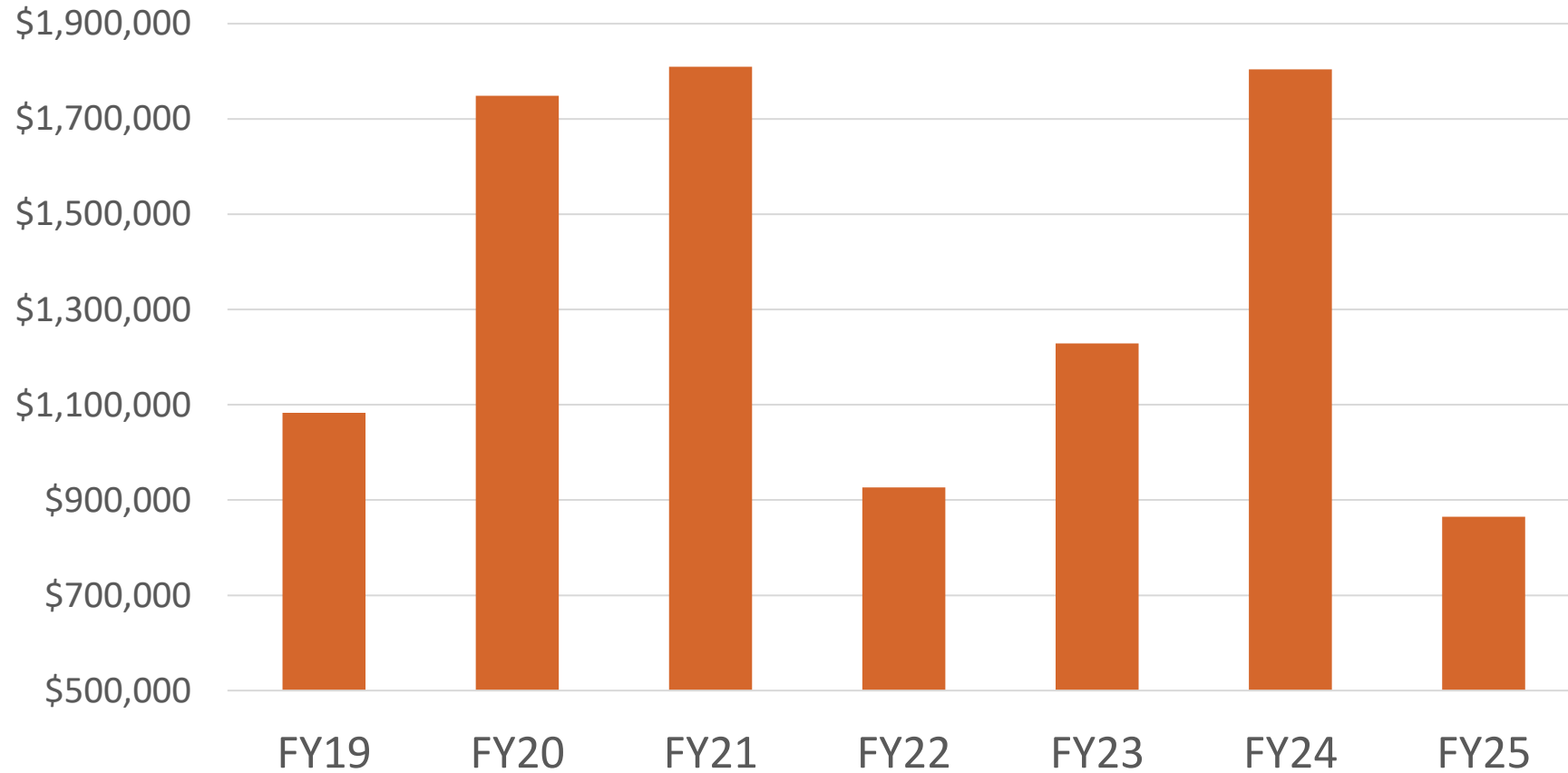



Cost to Taxpayers*

Market Value	Taxable Value	Park Millage	Police & Fire Millage	Total
\$200,000	\$100,000	\$65	\$146	\$211
\$250,000	\$125,000	\$82	\$183	\$264
\$300,000	\$150,000	\$98	\$219	\$317
\$350,000	\$175,000	\$114	\$256	\$370
\$400,000	\$200,000	\$130	\$292	\$423
\$500,000	\$250,000	\$163	\$365	\$528

**Property taxes based on market value of home, may be less due to below market taxable values resulting from Proposal A (1994) inflationary limits*



Questions and Discussion